

we redefine

Vibratory Finishing

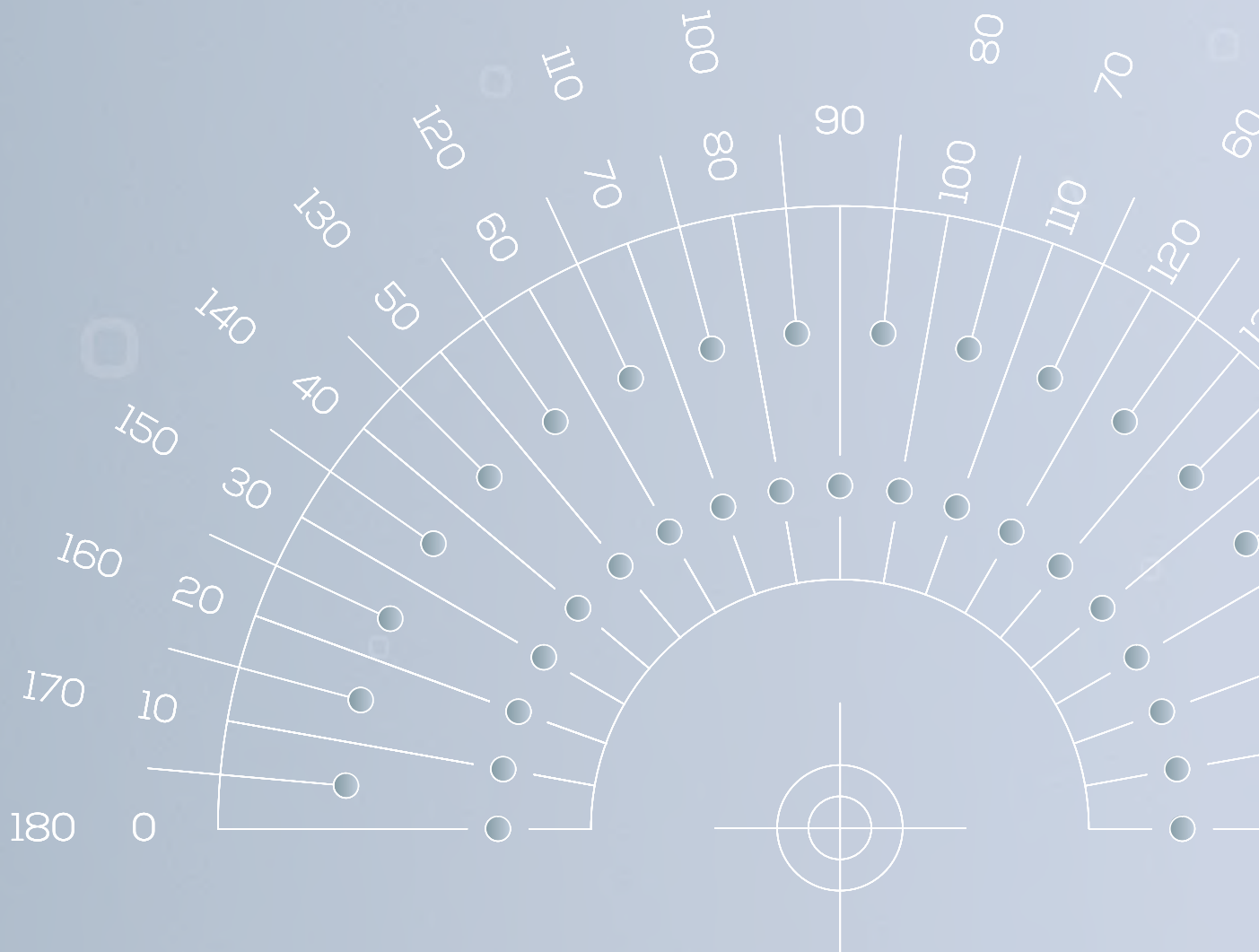

We're the UK's leading experts in designing and developing machinery and consumables for mass finishing applications.

we redefine:

- Aerospace
- Automotive
- Coin blanking
- Fashion
- General Engineering
- Hospitality
- Manufacturing
- Medical

and more...

Why Choose Us?

We're a family run business that pride ourselves on working as a strong, unified team of specialists.

We believe in British

Born in the United Kingdom, we are unique in our product design and the manufacture of our specialist machines and consumables.

We're here for you

Being based in the heart of the country means we have easy access to all of our clients.

We have experience

With five decades of experience and knowledge in the finishing industry, we know what works for you.

We provide options

We have an impressive range of media and compounds to choose from, including one of the best polishing compounds in the market. We also provide a wide range of machinery and subcontract services to meet all of your needs.

We go the extra mile

We'll tailor our services to your needs, not the other way round. Our service is all about you.



What is Mass Finishing?

Mass finishing is a process that automates the mechanical and chemical finishing of various shaped parts. This is a stage in the manufacturing process of components, which allows large numbers of parts to be finished simultaneously.

The aim of this process can vary based on the type of application, which include:

- ✓ high stock removal
- ✓ deburring
- ✓ descaling
- ✓ removal of machining lines
- ✓ removal of surface defects
- ✓ radius formation
- ✓ super-finishing

The processes can be configured as a batch system or a continuous system. Parts that are processed using a batch system will be loaded into the machine, processed and unloaded before the next batch is ready. This continuous system is a process where the parts are loaded at one end, and come out at the other end in the finished condition.

By combining our complete process knowledge with decades of experience, and our all-encompassing range of machinery, we can deliver the most optimum, cost-effective and environmentally friendly finishing solution for your needs.

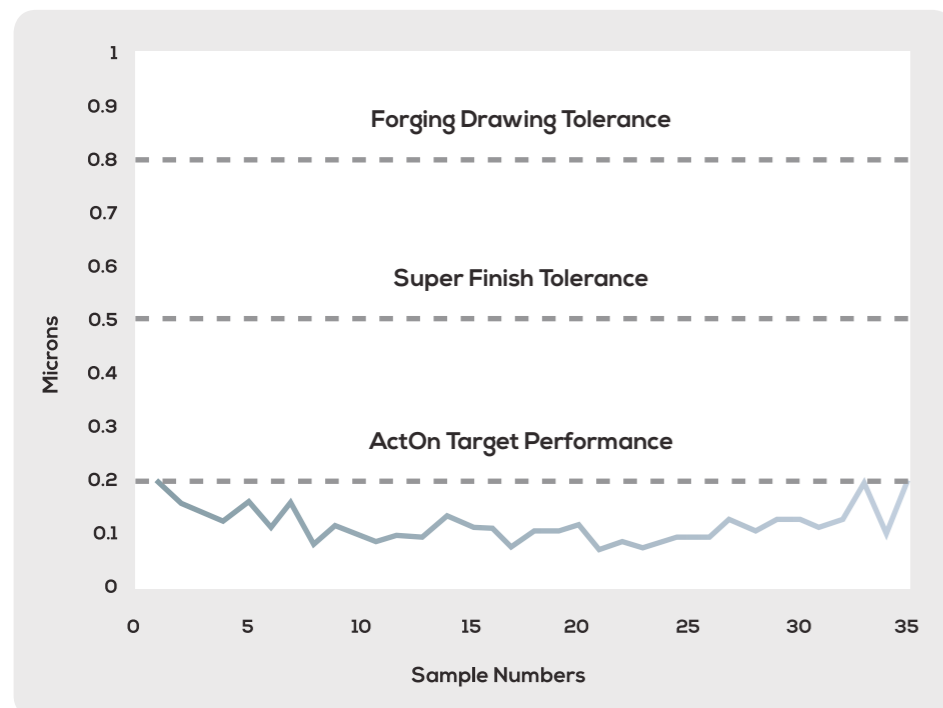

$$\underline{\text{Man}} \times \underline{\text{Machine}} \times \underline{\text{Media}} = M^3$$

Almost all manufactured components have experienced some surface improvement to ensure that these are in an acceptable condition for the end-user.

We understand the important of surface finishing for engines, and have worked closely with major manufacturers in the industry to adapt and develop finishing solutions that meet their stringent requirements. It has been proven that the solutions we've developed have benefited the industry by reducing processing times and producing a repeatable and quality product.

Surface Finishing is Critical in Keeping Manufactured Components Repeatable

Manufacturing companies usually implement mass finishing techniques in their processes for the economic advantages, and the consistent results achieved. Manual finishing processes are known to be labour intensive, with the disadvantages of rework high part rejects rates and inconsistent results. Having identified the issues, we offer a wide range of unique solutions that improve current processes, achieving the repeatability and quality desired by manufacturers.

ActOn Research and Development

We are continually evolving our processes and machines, making them more effective. We also have academic connections throughout the United Kingdom and around the world, who help facilitate our Research and Development department, where we house various metrological equipment to ensure that our customers' requirements are met and exceeded.

With projects involving modal and dynamic FEA analysis of our Vibratory machines, and the persistent gathering of empirical data on our various compounds, medias and machines, we strive to design and optimise everything we do to a high standard.

FEA Analysis

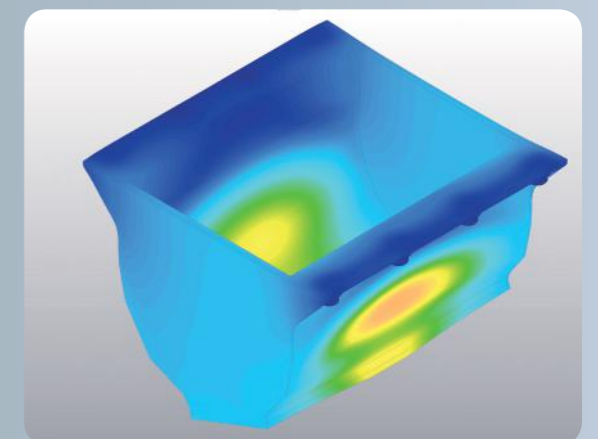
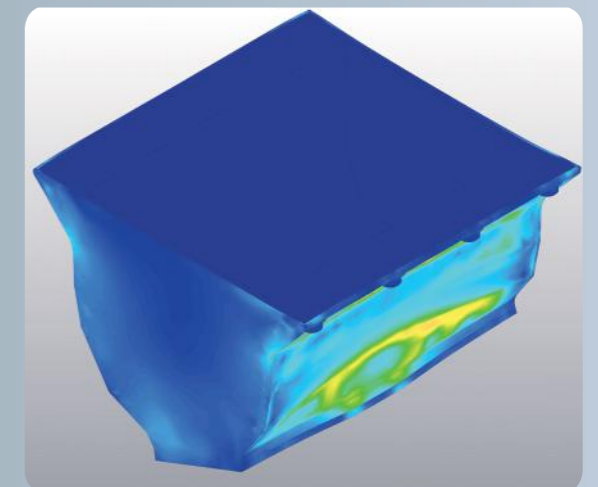

Vibratory Applications

Deburring

Descaling

Degreasing & Oil Removal

Cleaning

Smoothing

Radiusing

Brightening

Polishing

Drying

Corrosion Protection

Turbocut

For rapid removal of surface defects on ferrous parts.

Chemcut

For the quick improvement of the surface finish (Ra values) on ferrous parts.

ActoGrind

For heavy removal of grinding lines using mass finishing methods.

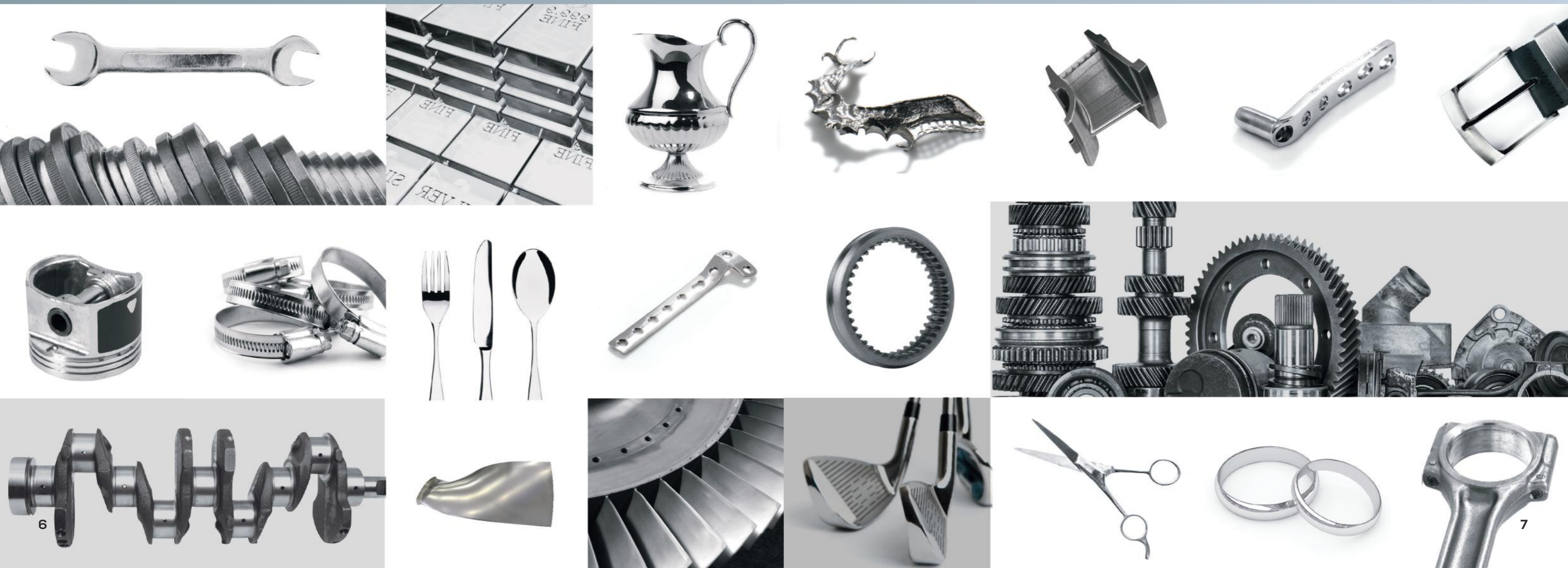

Bowls

Each of our Bowls is simple to operate and highly efficient, coming in classic designs and sizes to meet your unique applications.

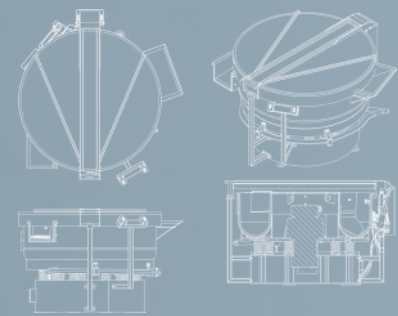

Troughs

We offer Troughs in many different sizes and an infinite choice of length and width combinations, making them one of our most versatile ranges.

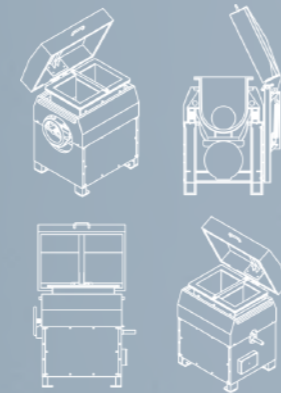

Duals

The orbital Dual finisher works to both deburr and dry in one single unit. This is both an excellent and economical finishing option.



Dryers

Our unique, elliptical-shaped Vibratory bowl drying machines suit a variety of finishing needs. Our machines are compact in size and simple to operate.

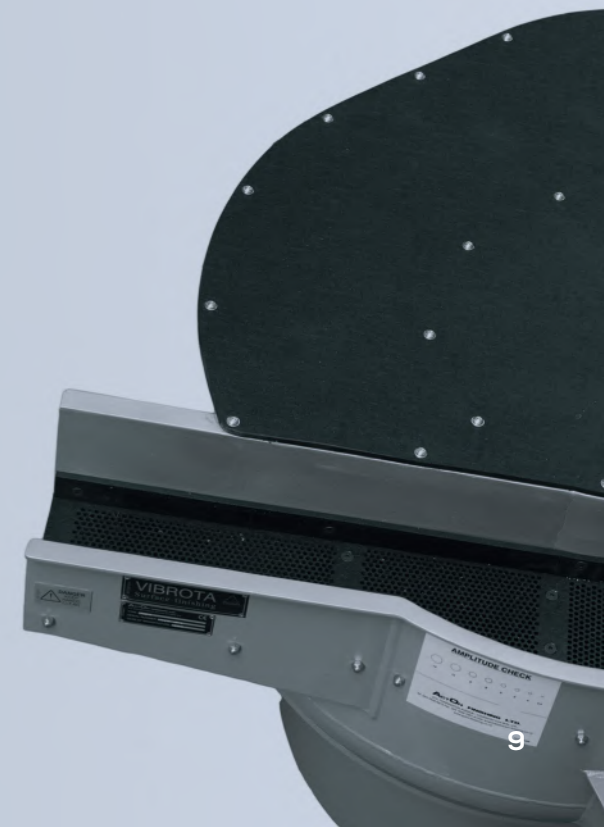
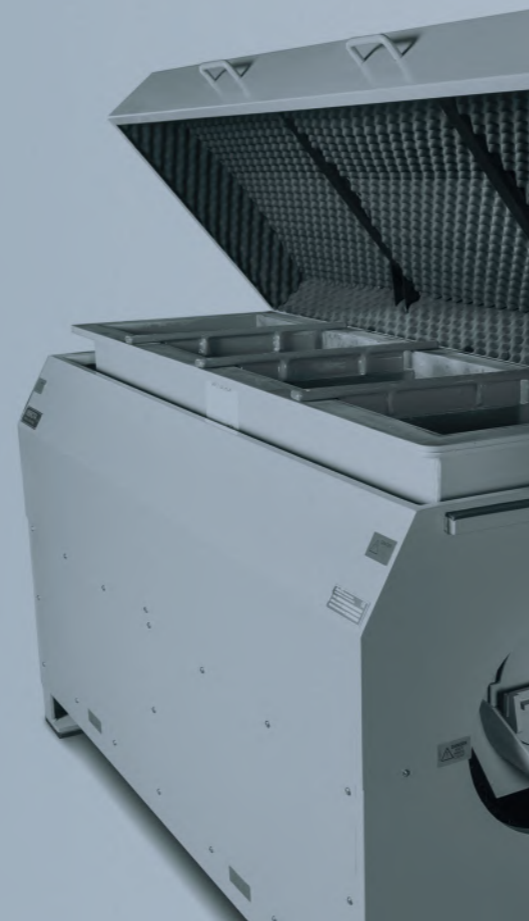
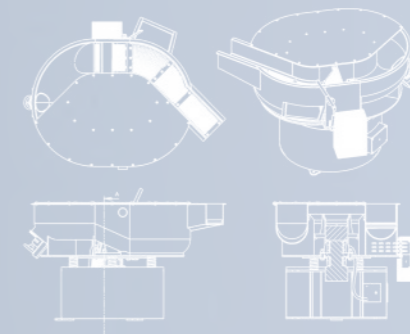

Vibratory Bowls

Process Chamber

- The internal chamber section has been designed in a manner that the components are subjected to effective tumbling action which ensures shorter process times.
- Process bowls stress relieved to improve life.
- Design ensures ease of customisation.

Acoustic Lid

The acoustic lid uses a custom designed acoustic foam which has improved properties of sound absorption thereby, keeping the machines quiet in operation and reducing costs on any additional noise deadening enclosures. The lid can be operated manually or pneumatically.

Pneumatic Separation system

With auto separation, it is advisable that this option is used. Reversing the rotational direction of the motor ensures the contents in the process chamber move in the opposite direction of the separation area thereby clearing the path for the flap to be seated correctly. This ensures no parts are being trapped under the flap, or any damage to the flap system.

Separation System with Accessories

The system comprises of a polyurethane flap with handle. Post process, the separation flap is engaged manually or pneumatically, and hence forms a bridge that assists parts to travel onto the separation screen while the machine is still vibrating. The media is then screened through the separation screen (holes or slots) and is retained in the bowl, whilst the parts exit from the machine.

- Separation screens can be manufactured out of various materials with openings to suit the geometry of the components being processed. Typical openings are holes and slots.
- Screens are reinforced making them sturdy to handle the weight of the parts.
- Removal of screens with our wedge type locking system reduces down time.
- Inverse separation screens are also used for applications where the media size is larger than the parts to facilitate effective separation.
- Spray bar with nozzles over the separation screen can be used to clean the parts prior to discharge from the machine.
- Air knife assists in pushing back any residual media that may be carried over by the parts on the screen and also assists in the removal of excessive water on the components.

Work Bowl Drain

The work bowl drain is polyurethane casted with openings to suit the media geometry. These drain designs allow effective discharge of the effluent to ensure that the process is clean and effective.

Suspension

Stable machine base incorporates special arrangement for locating the springs - ensuring stability to the process chamber when the machine is running - It is worth noting that there is no need to bolt it to the floor.

Discharge Door

The discharge door can be used to either remove media or both media and parts based on the application. The metal door has a polyurethane cast with sealing to ensure there is no leak during the process.

The operation of the door can be done either manually or pneumatically.

Lining

Bowl lining is important to ensure the fabrication is protected and that the components are effectively processed. ActOn has its special grade polyurethane materials formulated, which enhance the overall life of the machine. Either hot cured cast lining or spray lining can be provided up to 30 mm in processing areas.

Use of the high wear resistant polyurethane materials reduces the coefficient of friction between the media and bowl, thereby increasing media life expectancy.

- ActOn Finishing offers a wide range of cast systems to choose from, where variables such as shore hardness range, physical properties, and chemical resistance can be selected for particularly difficult applications.
- Wedge profile lining which is beneficial for processes that involve small delicate parts or part on part processes by preventing parts from sticking to the outer wall of the process chamber.

Dosing Unit

The system is capable of handling all types of ActOn's liquid compounds to the vibratory finishing machines giving a clean component, extended media life and also keeps the work bowl of the machine clean.

The diaphragm dosing pump controls the liquid compound flow rate dosed in to the bowl machine. The pump is usually wired through to the start button of vibratory machines. Once set, the pump gives accurate control of the liquid compound usage thereby reducing wastage and saving costs.

- Floor-mounted or wall-mounted dosing units are available.
- To comply with local Water Authority regulations the liquid compound and water are dosed separately to the vibratory equipment via a dual feed system, eliminating the need to fit expensive header tanks.

Control System

To suit functionality of the machine, suitable control systems are used. These control systems could be either operated via a push button system or via a touch screen using PLC control systems.

Most standard machines come with a standard control panel with a timer facility to set the process time.

Settlement Tank

The Settlement tank is connected to the drain of the finishing machine and the effluent is discharged from the vibratory machine into this tank. Baffle Plates are provided to assist settlement.

- Solids that settle out in the tank chamber can then be removed with ease by the operator with the optional removable baskets.
- Ergonomical and easy to use.
- Pump to transfer the liquid to the water treatment area (optional).
- Available in painted or stainless steel versions (optional).

Drive System

The work bowl, has a powerful heavy-duty, both sides extended shaft, flange mounted vibratory motor fitted on to it to impart powerful and uniform vibrations to the mass in the bowl. Due to these vibrations, this mass moves along a rotary and spiral path inside the work bowl thereby causing the media to continuously be in contact with the components resulting in effective processing in the shortest time.

- The vibratory motor is the heart of the machine. It is designed and manufactured to meet the duty conditions. Special castings and bearings form the assembly of these motors making them mechanically robust and reliable.

Undersized Media Separation

Due to media wear there is a mix of large and small media in the bowl. In such conditions there is a risk of lodgement and damage to certain parts. All media is passed through a screening device located at the bottom of the bowl while the finishing machine is running. The undersized media can thus be separated using a suitable size grid.

Imbalance weights

The upper and lower imbalance weights are securely fastened to both ends of the motor shaft and are adjustable to suit the process parameters.

Each of our Bowls are simple to operate and highly efficient.

These machines have been built to suit various customer applications from deburring, descaling, radiusing and cleaning to polishing and surface improvement.

We have set a high standard when designing and building the bowl machines and are highly committed to continuously develop our machines to suit most of the challenging finishing applications.

Machines are built to various standard sizes. Custom applications where size or configuration alteration is required, ActOn engineers would be pleased to assist.

Key Benefits:

- ✓ British built high-quality product
- ✓ Efficient in operation
- ✓ Quiet in operation
- ✓ High quality wear-resistant polyurethane lining
- ✓ Operator friendly controls
- ✓ Low maintenance
- ✓ Manual / Auto functionality
- ✓ Customised to suit user applications

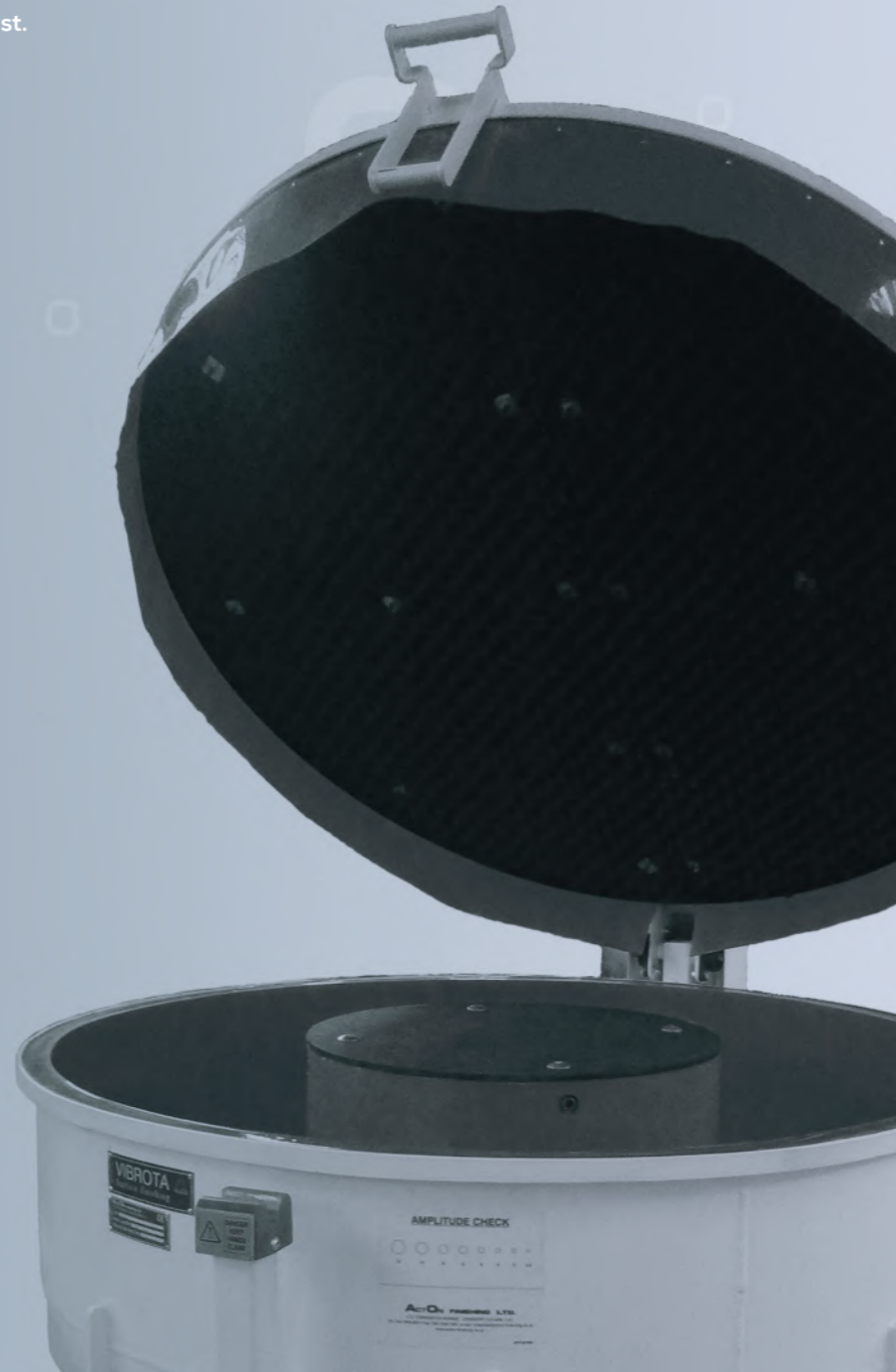

O Series

Standard bowls

Both large and small batches of components can be processed in this machine, where manual separation is mandatory. These machines are designed and manufactured with a single speed motor as a standard feature, with adjustable flyweights set to transfer the optimum amount of energy to produce a finish in the most efficient manner.

Please refer to page 44 and 45 for further information on the standard and optional features available on this series of machines.

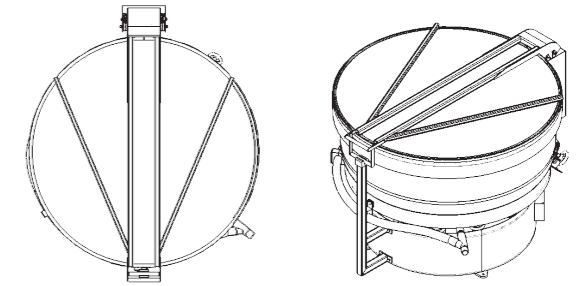

Series	Model	Capacity		Overall dimensions in mm/ inch			Chamber dimension in mm/ inch after lining		Max Motor Rating (kW)
		Cu. Ft.	Litres	Length	Width	Height	Width	Height	
O Series	VB3	3	85	1130 / 44.5	865 / 34	1080 / 42.5	250 / 9.8	290 / 11.4	2.2
	VB5	5	142	1455 / 57.2	1150 / 45.2	1175 / 46.3	230 / 9.1	350 / 13.8	2.2
	VB10	10	283.5	1690 / 66.5	1390 / 54.7	1170 / 46.1	330 / 13	465 / 18.3	4
	VB20	20	567	2070 / 81.5	1750 / 68.9	1270 / 50	365 / 14.4	515 / 20.3	7
	VB30	30	850	2300 / 90.6	1970 / 77.6	1425 / 56.1	400 / 15.7	565 / 22.2	7.5

Sizes indicated above are standard. Custom sizes can be manufactured to suit specific applications. Dimensions are subject to change due to design improvements.

S Series

Standard bowls

The S Series machine is used when processing batches of components that require a separation of components from the media. This is achieved via a mechanical flap arrangement which directs the media and components onto a separation grid. The grid has openings, which allow the media to return into the bowl and components to fall into the operator's receptacle. In certain applications, inverse separation is required.

Both large and small batches of components can be processed in this machine. These machines are designed and manufactured with a single/dual/variable speed motor to suit the application. The adjustable flyweights are set to transfer the optimum amount of energy to produce a finish in the most efficient manner.

Please refer to page 44 and 45 for further information on the standard and optional features available on this series of machines.

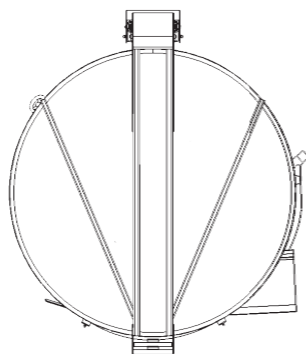
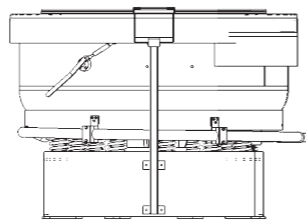

Series	Model	Capacity		Overall dimensions in mm/ inch			Chamber dimension in mm/ inch after lining		Max Motor Rating (kW)
		Cu. Ft.	Litres	Length	Width	Height	Width	Height	
S Series	VB3S	3	85	1130 / 44.5	900 / 35.4	1080 / 42.5	250 / 9.8	290 / 11.4	2.2
	VB5S	5	142	1455 / 57.3	1150 / 45.3	1175 / 46.3	230 / 9.1	350 / 13.8	2.2
	VB10S	10	283.5	1690 / 66.5	1475 / 58.1	1235 / 48.6	330 / 13	515 / 20.3	4
	VB20S	20	567	2070 / 81.5	1750 / 68.9	1270 / 50	365 / 14.4	515 / 20.3	7
	VB30S	30	850	2300 / 90.5	1970 / 77.5	1425 / 56.1	400 / 15.7	565 / 22.2	7.5

Sizes indicated above are standard. Custom sizes can be manufactured to suit specific applications. Dimensions are subject to change due to design improvements.

Bench Mounted Series

These machines are ideally suited for small batch works and are capable of deburring, burnishing, radiusing, descaling, polishing, cleaning and surface improvement.

The bowl is cast as a single moulding and is extremely robust in its construction. Where there is more than one machine located, ActOn could supply different polyurethane colours for operator convenience of differentiating part types.

The machine operates via a standard DOL starter and is easy to operate. Both O series and S series type machines are in our range of manufacture. The S series type can be integrated with a bench drier.

Please refer to page 44 and 45 for further information on the standard and optional features available on this series of machines.

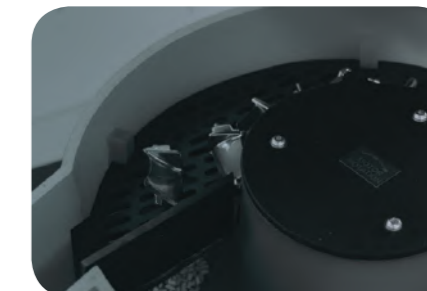
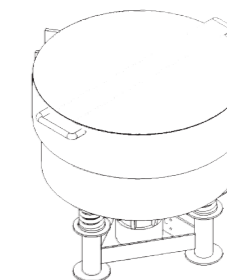
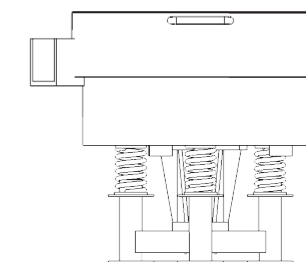

Series	Model	Capacity		Overall dimensions in mm/ inch			Chamber dimension in mm/ inch after lining		Max Motor Rating (kW)
		Cu. Ft.	Litres	Length	Width	Height	Width	Height	
Bench Mounted Series	VB1	1	28	730 / 28.7	630 / 24.8	600 / 23.6	150 / 5.9	230 / 9.1	0.18
	VB1S	1	28	730 / 28.7	700 / 27.5	600 / 23.6	150 / 5.9	230 / 9.1	0.18

Sizes indicated above are standard. Custom sizes can be manufactured to suit specific applications. Dimensions are subject to change due to design improvements.

B Series

The ball burnishing machine has been specially designed for burnishing application using stainless steel media or a mix of burnishing media.

The machines are designed to suit this heavy duty application with a powerful drive system and special springs. The bowl has a special rubber lining to assist the movement of the parts during the process.

Machines can be manufactured with or without separation to suit the applications.

Please refer to page 44 and 45 for further information on the standard and optional features available on this series of machines.

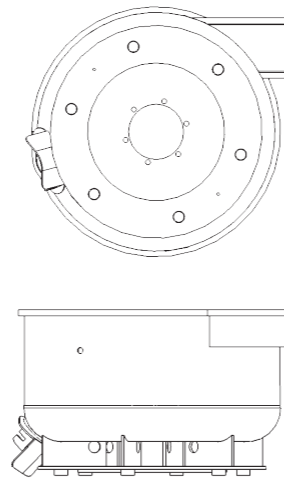
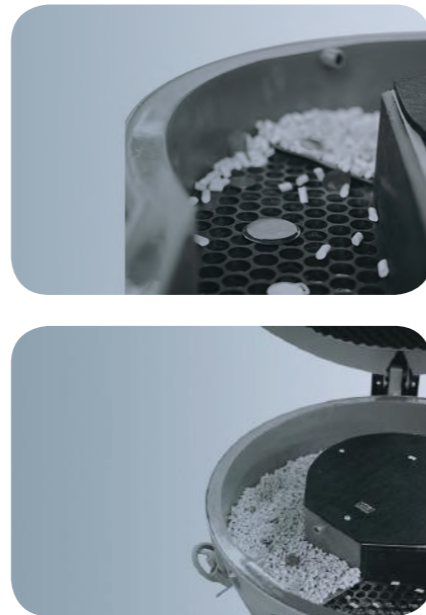

Series	Model	Capacity		Overall dimensions in mm/ inch			Chamber dimension in mm/ inch after lining		Max Motor Rating (kW)
		Cu. Ft.	Litres	Length	Width	Height	Width	Height	
B Series	VB3B	3	85	1130 / 44.5	865 / 34.1	1080 / 42.5	250 / 9.8	290 / 11.4	2.2
	VB3S B	3	85	1130 / 44.5	900 / 35.4	1080 / 42.5	250 / 9.8	290 / 11.4	2.2
	VB5B	5	142	1455 / 57.3	1150 / 45.3	1175 / 46.3	230 / 9.1	350 / 13.7	2.2
	VB5S B	4.4	125	1455 / 57.3	1150 / 45.3	1075 / 42.3	230 / 9.1	250 / 9.8	2.2
	VB10B	10	283.5	1690 / 66.5	1390 / 54.7	1170 / 46.1	330 / 12.9	465 / 18.3	4
	VB10S B	10	240	1690 / 66.5	1475 / 58.1	1170 / 46.1	330 / 12.9	465 / 18.3	4
	VB20B	20	567	2070 / 81.5	1750 / 68.9	1270 / 50	365 / 14.4	515 / 20.3	7
	VB20S B	20	500	2070 / 81.5	1750 / 68.9	1200 / 47.2	365 / 14.4	465 / 18.3	7
	VB30B	30	850	2300 / 90.5	1970 / 77.5	1425 / 56.1	400 / 15.7	565 / 22.2	7.5
	VB30S B	30	775	2300 / 90.5	1970 / 77.5	1350 / 53.1	400 / 15.7	515 / 20.3	7.5

Sizes indicated above are standard. Custom sizes can be manufactured to suit specific applications. Dimensions are subject to change due to design improvements.

C Series

This series of machines has a narrower central section of the working bowl, which allows the processing of large circular components such as vane rings. There is no need to fixture the component while being processed.

One standard size of machine is manufactured to accommodate a component with a bore ID 250 mm and an overall OD not larger than 940 mm.

Please refer to page 44 and 45 for further information on the standard and optional features available on this series of machines.

Available models in the C Series: ✓ VB5C

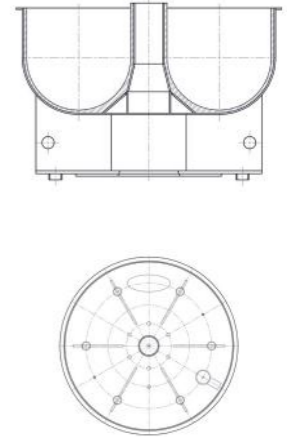
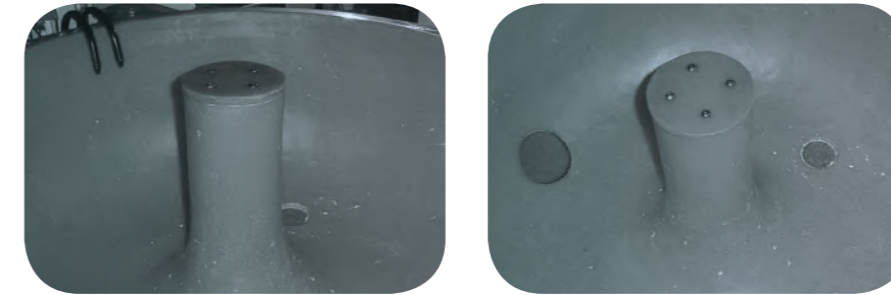

I Series

The I Series machines are unique in concept and are ideal for processing components to avoid any impingement damages. Components are manually loaded / unloaded in each chamber.

Please refer to page 44 and 45 for further information on the standard and optional features available on this series of machines.



Series	Model	Capacity		Overall dimensions in mm/ inch			Chamber dimension in mm/ inch after lining		Max Motor Rating (kW)
		Cu. Ft.	Litres	Length	Width	Height	Width	Height	
I Series	VB1I	1	28	730 / 28.7	630 / 24.8	600 / 23.6	150 / 5.9	230 / 9.1	0.18
	VB3I	3	85	1130 / 44.5	865 / 34	1080 / 42.5	250 / 9.8	290 / 11.4	2.2
	VB5I	5	142	1455 / 57.2	1150 / 45.2	1175 / 46.3	230 / 9.1	350 / 13.8	2.2
	VB10I	10	283.5	1690 / 66.5	1390 / 54.7	1170 / 46.1	330 / 13	465 / 18.3	4
	VB20I	20	567	2070 / 81.5	1750 / 68.9	1270 / 50	365 / 14.4	515 / 20.3	7
	VB30I	30	850	2300 / 90.6	1970 / 77.6	1425 / 56.1	400 / 15.7	565 / 22.2	7.5

Sizes indicated above are standard. Custom sizes can be manufactured to suit specific applications. Dimensions are subject to change due to design improvements.

M Series

The M Series machines allow you to separate parts from media using an overband electro-magnetic separator. The process of separation and demagnetisation is automated giving the required control of process. The machines are designed with a higher ramp, allowing smaller parts to be separated magnetically.

The Overband Electromagnetic Component Separator comprises of a weld/bolted fabricated carbon steel chassis mounted on a combination of heavy duty fixed and swivelling type castor wheels with polyurethane tread. The conveyor assembly, incorporating the electromagnetic head, is suspended from the topmost chassis cross member using a heavy duty roller chain. Vertical movement of the conveyor assembly, including the electromagnetic head assembly and demagnetizing coil, is provided by an electrically operated linear type actuator.

The actual magnetic head is built to our exclusive design from high permeability annealed magnet steel and energized by coil assemblies wound using synthetic enamel varnish insulated high conductivity electrolytic grade copper wire. The winding material is insulated from the steel cores with several layers of high grade Class F insulating material and the complete wound assemblies vacuum impregnated, thus rendering them impervious to the ingress of dust, dirt and moisture. Located toward the discharge end of the conveyor unit is a mounted, totally enclosed aperture type de-magnetizing coil.

The belt we supply and fit has a multi-ply polyester carcass with a moulded flexible polyurethane grip working face. The belt is made endless with special, non-magnetic grade stainless steel clips and lacing cord. Drive for the belt is provided by a motorised type drive pulley located at the discharge end. Special, polyurethane rollers mounted on non-magnetic grade stainless steel shafts and carried in bearing assemblies are included at the top and bottom positions of the head unit and at the back of the actual magnet assembly to achieve the desired belt track and contour.

Please refer to page 44 and 45 for further information on the standard and optional features available on this series of machines.

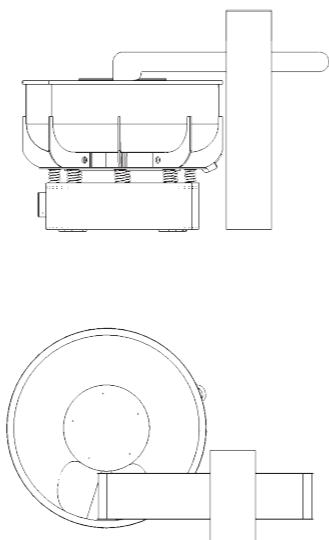

Series	Model	Capacity		Overall dimensions in mm/ inch			Chamber dimension in mm/ inch after lining		Max Motor Rating (kW)
		Cu. Ft.	Litres	Length	Width	Height	Width	Height	
M Series	VB10M	10	283.5	1690 / 66.5	1390 / 54.7	1170 / 46.1	330 / 12.9	465 / 18.3	4
	VB20M	20	567	2070 / 81.5	1750 / 68.9	1270 / 50	365 / 14.4	515 / 20.3	7
	VB30M	30	850	2300 / 90.5	1970 / 77.5	1425 / 56.1	400 / 15.7	565 / 22.2	7.5

Sizes indicated above are standard. Custom sizes can be manufactured to suit specific applications. Dimensions are subject to change due to design improvements.

P Series

This series is a variant of the O series, but is more robust and has been designed for a process where 100% discharge of media and part is required at the end. These machines can be used for part-on-part application to unload the parts at the end of the process.

On completion of the process, the pneumatically operated door will open and allow the parts and media to 100% discharge from the bowl.

The P series machines can also be automated to allow for component / media separation via a series of auxiliary equipment and auto return of the media to the bowl. Our engineers would be pleased to customise a solution to suit your needs.

Please refer to page 44 and 45 for further information on the standard and optional features available on this series of machines.

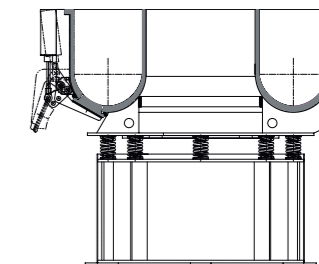

Series	Model	Capacity		Overall dimensions in mm/ inch			Chamber dimension in mm/ inch after lining		Max Motor Rating (kW)
		Cu. Ft.	Litres	Length	Width	Height	Width	Height	
P Series	VB3P	3	85	1075 / 42.3	865 / 34.1	1080 / 42.5	250 / 9.8	290 / 11.4	2.2
	VB5P	5	142	1400 / 55.1	1150 / 45.3	1175 / 46.3	230 / 9.1	350 / 13.7	2.2
	VB10P	10	283.5	1600 / 62.9	1390 / 54.7	1170 / 46.1	330 / 12.9	465 / 18.3	4

Sizes indicated above are standard. Custom sizes can be manufactured to suit specific applications. Dimensions are subject to change due to design improvements.

Vibratory Troughs

Divider Plates

The work chamber can be sub-divided using divider plates to provide separate compartments for precision or delicate components, yet providing a highly efficient machine capable of batch processing.

- Fully Polyurethane coated.
- The divider plate fixture system has been designed to offer flexibility in changing the chamber size to suit the part geometry.

Process Chamber

- The internal chamber "U" section has been designed in a manner that the components are subjected to effective tumbling action that ensures shorter process times. Process chambers are stress relieved to improve life.
- Design ensures ease of customisation.
- Easy to access working chamber.
- Gives flexibility to process large or irregular components.

Control System

To suit functionality of the machine, suitable control systems are used. These control systems could be either operated via a push button system or via a touch screen using PLC control systems.

Most standard machines come with a standard control panel with a timer facility to set the process time.

Settlement Tank

The Settlement tank is connected to the drain of the finishing machine and the effluent is discharged from the vibratory machine into this tank. Baffle Plates are provided to assist settlement.

- Solids which settle out in the tank chamber can then be removed with ease by the operator with the optional removable baskets.
- Ergonomical and easy to use.
- Pump to transfer the liquid to the water treatment area (optional).

Available in painted or stainless steel versions (optional).

Drive system

The work chamber, has a powerful heavy-duty, both sides extended shaft, foot mounted vibratory motor fitted on to it to impart powerful and uniform vibrations to the mass in the trough. Due to these vibrations, this mass moves along a linear and spiral path inside the work chamber thereby causing the media to continuously be in contact with the components, which results in effective processing in the shortest time.

- The vibratory motor is the heart of the machine. It is designed and manufactured to meet the duty conditions. Special castings and bearings form the assembly of these motors making them mechanically robust and reliable.

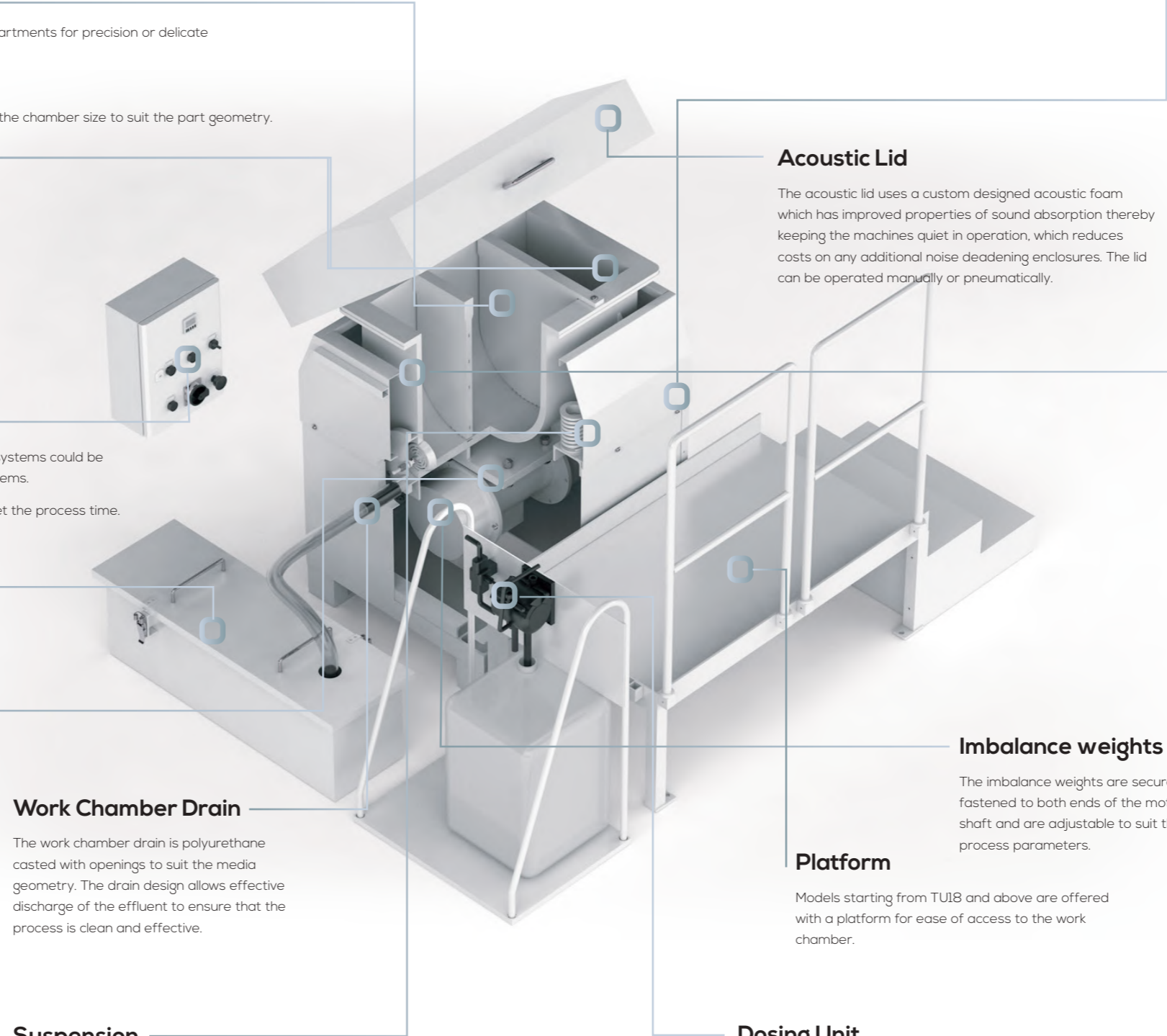

Discharge Door

The discharge door can be used to either remove media or both media and parts based on the application. The metal door has a polyurethane cast with sealing to ensure there is no leak during the process.

The operation of the door can be done either manually or pneumatically.

Due to media wear there is a mix of large and small media in the work chamber. In such conditions, there is a risk of lodgement and damage to certain parts. All media can be discharged through this door and passed through an auxiliary screening device while the trough machine is running. The undersized media can thus be separated using a suitable size grid on the screening machine.

Lining

Trough lining is important to ensure the fabrication is protected and also the components are effectively processed. ActOn has its special grade polyurethane materials formulated that enhance the overall life of the machine. Either hot cured cast lining or spray lining can be provided - up to 30 mm in processing areas. Use of the high wear resistant polyurethane materials reduces the coefficient of friction between the media and processing chamber, thereby increasing media life expectancy.

- ActOn Finishing offers a wide range of cast systems to choose from, where variables such as shore hardness range, physical properties, and chemical resistance can be selected for particularly difficult applications.
- Wedge profile lining, which is beneficial for processes that involve small delicate parts or part-on-part processes by preventing parts from sticking to the outer wall of the process chamber.

Acoustic Lid

The acoustic lid uses a custom designed acoustic foam which has improved properties of sound absorption thereby keeping the machines quiet in operation, which reduces costs on any additional noise deadening enclosures. The lid can be operated manually or pneumatically.

Imbalance weights

The imbalance weights are securely fastened to both ends of the motor shaft and are adjustable to suit the process parameters.

Platform

Models starting from TU18 and above are offered with a platform for ease of access to the work chamber.

Part Fixture

For processing multiple sensitive parts, ActOn offers the option of a special fixture to mount the components onto.

- Avoiding part-on-part process.
- Protects components during the process from contact with the side walls of the process chambers.

Work Chamber Drain

The work chamber drain is polyurethane casted with openings to suit the media geometry. The drain design allows effective discharge of the effluent to ensure that the process is clean and effective.

Suspension

A stable machine base incorporates a special arrangement for locating the springs, which ensures stability to the process chamber when the machine is running low. There is no need to bolt it to the floor either.

Dosing Unit

The system is capable of handling all types of ActOn's liquid compounds to the vibratory finishing machines giving a clean component, extended media life and also keeps the work chamber of the machine clean.

The diaphragm dosing pump controls the liquid compound flow rate dosed in to the trough machine. The pump is usually wired through to the start button of vibratory machines. Once set, the pump gives

accurate control of the liquid compound usage thereby reducing wastage and saving costs.

- Floor-mounted or wall-mounted dosing units are available.
- To comply with local Water Authority regulations the liquid compound and water are dosed separately to the vibratory equipment via a dual feed system, eliminating the need to fit expensive water tanks.

The trough machine is perfect for larger, longer and irregular-shaped components.

Offered in various standard sizes and a choice of combination of lengths and widths, the troughs are the most versatile machines. These machines have been built to suit various customer applications from deburring, descaling, radiusing and cleaning to polishing and surface improvement.

We have set a high standard when designing and building the trough machines and are highly committed to continuously develop our machines to suit most of the challenging finishing applications.

Machines are built to various standard sizes. If there are custom applications where size or configuration alteration is required, ActOn engineers would be pleased to assist.

Key Benefits:

- ✓ British built, high-quality product
- ✓ Efficient in operation
- ✓ Quiet in operation
- ✓ High quality, wear resistant polyurethane lining
- ✓ Operator friendly controls
- ✓ Low maintenance
- ✓ Manual / Auto functionality
- ✓ Customised to suit user applications
- ✓ Several processing chambers can be made with use of dividers
- ✓ Solutions include both batch type and continuous online systems



HT Series

These machines are ideally suited for small batch works and delicate components. The machines house a work chamber which is polyurethane lined and works on the same principle as the TU series trough machines.

The machines are mounted on castor wheels and can be moved with ease. The unit also has its own recirculating tank with pump for dosing the mixture of water and compound for the process.

Generally quiet in operation, the machines run on a standard 16A socket, 1 phase, 240V AC supply thus making it a very user friendly kit for deburring or burnishing operation.

Please refer to page 44 and 45 for further information on the standard and optional features available on this series of machines.

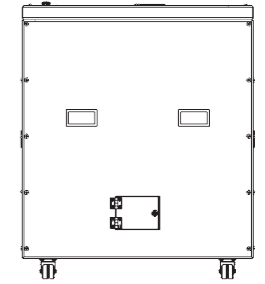
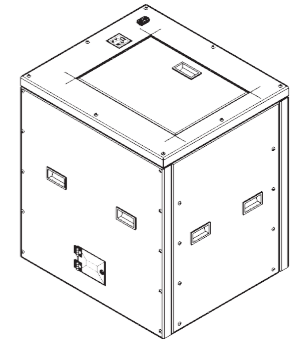

Series	Model	Capacity		Overall dimensions in mm/ inch			Trough dimension in mm/ inch after lining			Max Motor Rating
		Cu. Ft.	Litres	Length	Width	Height	Length	Width	Height	
HT Series	HT2	2	60	825 / 32.5	725 / 28.5	971 / 38.2	575 / 22.6	395 / 15.5	368 / 14.5	0.34 kW - 1500 rpm 0.50 kW - 3000 rpm

Sizes indicated above are standard. Custom sizes can be manufactured to suit specific applications. Dimensions are subject to change due to design improvements.

TU Series

The TU series Trough Finishing Machines have been designed to be simple to operate and highly efficient. Both large and small batches of components can be processed in this machine, where manual separation is mandatory. These machines are designed and manufactured with a single speed motor as a standard feature with adjustable flyweights set to transfer the optimum amount of energy to produce a finish in the most efficient manner.

Several process chambers can be created in this rectangular polyurethane lined process chamber to suit part sizes and multiple media types.

Please refer to page 44 and 45 for further information on the standard and optional features available on this series of machines.

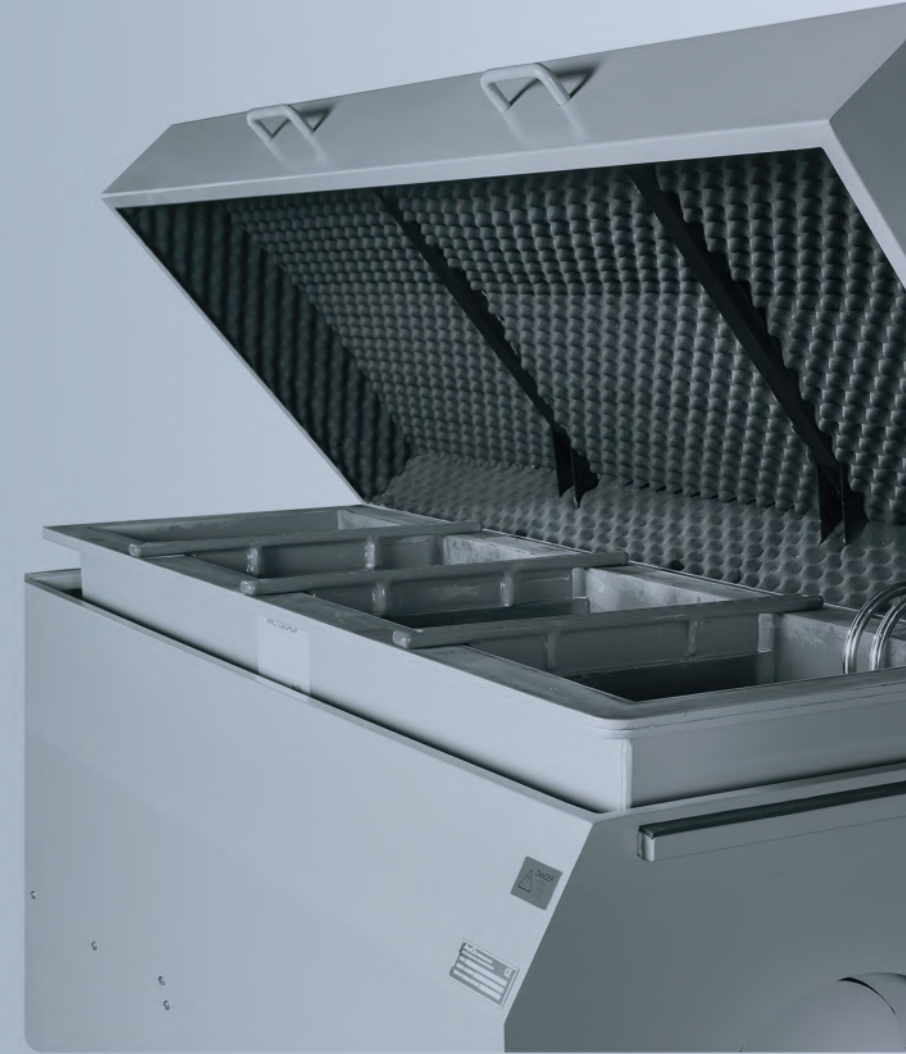
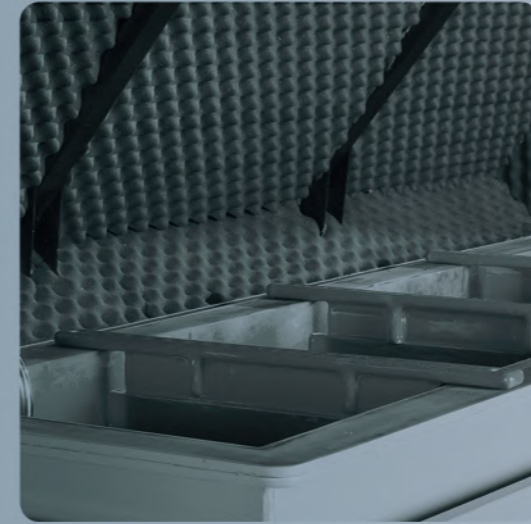
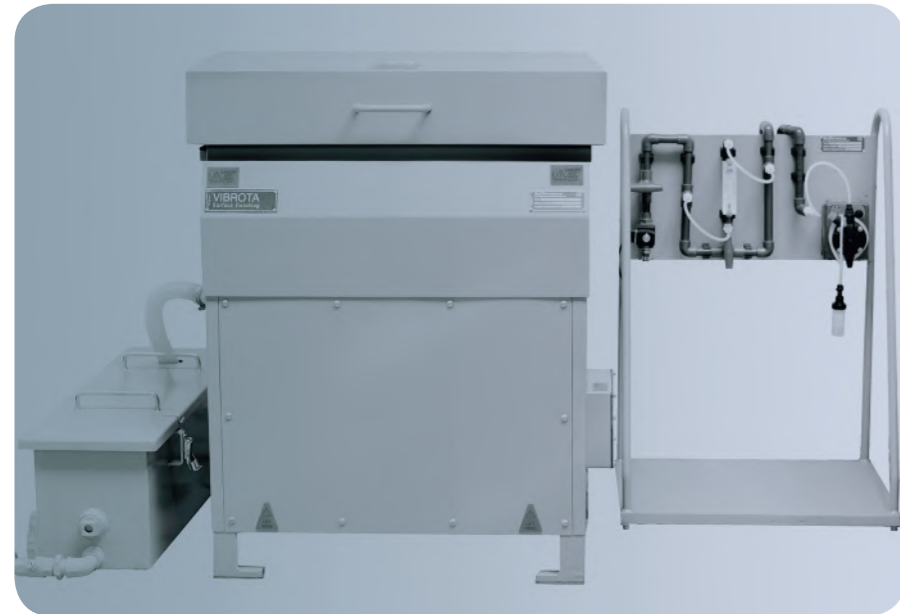
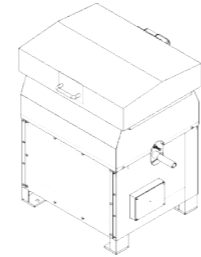
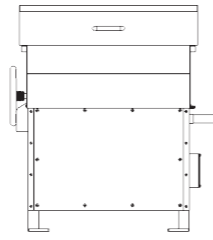

Series	Model	Capacity		Overall dimensions in mm/ inch			Trough dimension in mm/ inch after lining			Max Motor Rating (kW)
		Cu. Ft.	Litres	Length	Width	Height	Width	Height	Length	
	TU3	3	85	1000 / 39.4	850 / 33.5	1085 / 42.7	370 / 14.5	445 / 17.5	575 / 22.6	0.95
	TU4	4	113	1225 / 48.2	850 / 33.5	1085 / 42.7	370 / 14.5	445 / 17.5	800 / 31.5	1.2
	TU7	7	198	1725 / 67.9	850 / 33.5	1085 / 42.7	370 / 14.5	445 / 17.5	1300 / 51.2	1.7
	TU8	8	227	1415 / 55.7	1000 / 39.4	1280 / 50.4	450 / 17.7	560 / 22	930 / 36.6	2.2
	TU9	9	255	2075 / 81.7	850 / 33.5	1250 / 49.2	370 / 14.5	445 / 17.5	1650 / 64.9	2.2
	TU10	10	283	1670 / 65.7	1000 / 39.4	1280 / 50.4	450 / 17.7	560 / 22	1185 / 46.6	2.2
TU series	TU12	12	340	1325 / 52.1	1255 / 48.2	1485 / 58.5	645 / 25.4	710 / 27.9	895 / 35.2	2.2
	TU14	14	397	2135 / 84.1	1000 / 39.4	1280 / 50.4	450 / 17.7	560 / 22	1650 / 64.9	2.8
	TU18	18	510	1435 / 56.5	1400 / 55.1	1500 / 59.1	770 / 30.3	655 / 25.8	960 / 37.8	6
	TU20	20	567	1970 / 77.5	1255 / 48.2	1485 / 58.5	650 / 25.6	710 / 27.9	1540 / 60.6	6
	TU23	23	652	2175 / 85.6	1255 / 48.2	1535 / 60.4	645 / 25.4	710 / 27.9	1745 / 68.7	6
	TU23XW	23.5	666	2000 / 78.7	1400 / 55.1	1500 / 59.1	770 / 30.3	655 / 25.8	1520 / 59.8	6
	TU25	25	708	1380 / 54.3	1850 / 72.8	1980 / 77.9	1240 / 48.8	1070 / 42.1	940 / 37	7
	TU29	29	822	2680 / 105.5	1280 / 50.4	1570 / 61.8	645 / 25.4	710 / 27.9	2210 / 87	7
	TU30	30	850	2000 / 78.7	1400 / 55.1	1650 / 64.9	770 / 30.3	810 / 31.8	1520 / 59.8	7
	TU50	50	1417	3600 / 141.7	1350 / 53.1	1800 / 70.8	770 / 30.3	700 / 27.6	3000 / 118.1	11

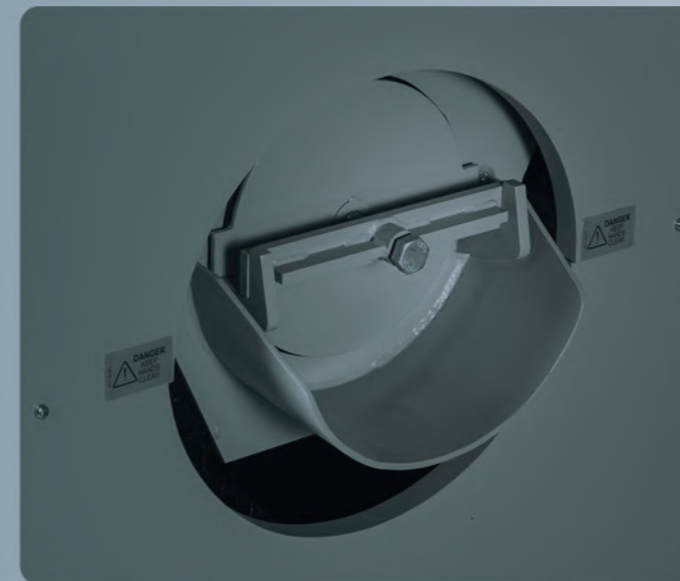

Dual Machine

Acoustic Lid

The acoustic lid uses a custom designed acoustic foam which has improved properties of sound absorption thereby keeping the machines quiet in operation and reducing costs on any additional noise deadening enclosures. The lid can be operated manually or pneumatically.

Lining

Reference description on page 10 and 11.

Settlement Tank

Reference description on page 10 and 11.

Inner Chamber (Wet)

- The internal chamber section has been designed in a manner that the components are subjected to effective tumbling action that ensures shorter process times.
- Process bowls stress relieved to improve life.
- Design ensures ease of customisation.

Outer Chamber (Dry)

Post processing the parts in the inner chamber; these are transferred into the outer chamber via the separation screen, to be dried.

Separation System

The system comprises of a polyurethane flap with handle. Post process the separation flap is engaged manually or pneumatically, and hence forms a bridge that assists parts to travel onto the separation screen while the machine is still vibrating. The media is then screened through the separation screen (holes or slots) and is retained in the bowl, while the parts are discharged to the outer chamber for drying. This operation is repeated once the parts have been processed in the outer chamber and then suitably collected.

- Separation screens can be manufactured out of various materials with openings to suit the geometry of the components being processed. Typical openings are holes and slots.
- Screens are reinforced making them sturdy to handle the weight of the parts.
- Removal of screens with our wedge type locking system reduces down time.

- Inverse separation screens are also used for applications where the media size is larger than the parts to facilitate effective separation.
- Spray bar with nozzles over the separation screen can be used to clean the parts prior to discharge from the machine.
- Air knife assists in pushing back any residual media that may be carried over by the parts on the screen and also assists in the removal of excessive water on the components.

Pneumatic Separation System

With auto separation, it is advisable that this option is used. Reversing the rotational direction of the motor ensures the contents in the process chamber move in the opposite direction of the separation area thereby clearing the path for the flap to be seated correctly. This ensures no parts are being trapped under the flap or any damage to the flap system.

Dosing Unit

Reference description on page 10 and 11.

Automatic Dispenser

Introducing materials into the inner chamber at the same volumes and times that can be controlled. In this instance, it is a separating compound that prevented the flat parts sticking to each other while being processed.

ActOn Dust Extractor for Maize Application

ActOn Dust Extractor is a self-contained collector built for collecting the fine dust resulting from the process carried out in the outer chamber.

- Quick to install and easy to maintain.
- Compact design.
- Minimizes floor space and fits in virtually any plant layout.
- Available in a standard version or with explosion relief system.
- Quiet & efficient operation.

Drive System

Reference description on page 10 and 11.

Parts Feeder

Stores a batch of parts and transfers the parts by a set weight into the machine inner process chamber. Once the process is complete, the next batch is discharged into the machine immediately.

Inner Chamber Drain

The work bowl drain is polyurethane casted with openings to suit the media geometry. These drain designs allow effective discharge of the effluent to ensure that the process is clean and effective.

Discharge Door

Reference description on page 10 and 11.

Suspension

Reference description on page 10 and 11.

Undersized Media Separation

Due to media wear, there is a mix of large and small media in the bowl. In such conditions, there is a risk of lodgement and damage to certain parts. All media is passed through a screening device located at the bottom of the bowl while the finishing machine is running. The undersized media can thus be separated using a suitable size grid.

Imbalance weights

Reference description on page 10 and 11.

Control System

To suit functionality of the machine, suitable control systems are used. These control systems can be either operated via a push button system or via a touch screen using PLC control systems. Most standard machines come with a standard control panel with a timer facility to set the process time.

This space-saving machine complements ActOn Finishing's range of vibratory surface finishing machines.

Key Benefits:

- ✓ British built, high-quality product
- ✓ Option to carry out both wet and dry process in one machine
- ✓ Efficient in operation
- ✓ Quiet in operation
- ✓ High quality, wear resistant polyurethane lining
- ✓ Operator friendly controls
- ✓ Low maintenance
- ✓ Manual / Auto functionality
- ✓ Customised to suit user applications



Dual Machine

The design integrates two process chambers: an inner chamber that can be used for wet process application, and the outer chamber for dry process applications, both of which make it easier to control. The inner chamber has a hot cured polyurethane lining and can be used from deburring, descaling, radiusing and cleaning to polishing and surface improvement.

The heated outer chamber can be used for drying/cleaning the parts after being processed in the inner chamber.

Parts can automatically be transferred from the inner chamber to the outer chamber.

Please refer to page 44 and 45 for further information on the standard and optional features available on this series of machines.

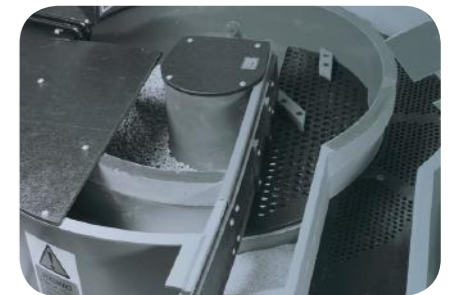

Series	Model	Bowl Capacity		Overall dimensions in mm/ inch			Process Chamber Dimensions in mm/ inch after lining		Drier Chamber Dimensions in mm/ inch		Max Motor Rating (kW)	Number of Heaters	Total Heater Rating (kW)
		Cu. Ft.	Litres	Length	Width	Height	Width	Height	Width	Height			
Dual Machine	Dual 3+3	3+3	85+85	1430 / 56.3	1240 / 48.8	1100 / 43.3	250 / 9.8	290 / 11.4	155 / 6.1	240 / 9.4	2.2	2 off	1.5 x 2
	Dual 5+5	5+5	142+142	1830 / 72	1500 / 59.1	1080 / 42.5	230 / 9.1	335 / 13.2	180 / 7.1	205 / 8.1	2.2	2 off	2 x 2

Sizes indicated above are standard. Custom sizes can be manufactured to suit specific applications. Dimensions are subject to change due to design improvements.

Dryer Machine

Process Chamber

- Metal spun process chamber.
- The elliptical shape of the process chamber gives more drying area in the machine, taking up less floor space.
- Stress relieved.
- Components can be loaded into the chamber through a side loading chute.
- Easily customisable to suit customer requirements.
- Various channel sizes and overall diameters to suit customers' application.

Imbalance weights

The upper and lower imbalance weights are securely fastened to both ends of the motor shaft and are adjustable to suit the process parameters.

Separation System

Upon completion of the process, the separation flap is engaged manually or pneumatically, allowing vibration to unload the parts over a separation screen. The agro media falls through the separation screen and returns into the bowl, while the parts are unloaded from the machine.

- Our separation screens are made out of polypropylene and the sizes of holes can be manufactured depending on the geometry of the part being processed.
- Our durable reinforced screens can be used for heavier parts.
- Screen mounted by wedges which make it vibration resistant and easily interchangeable.

Control System

Suitable control systems are used for each individual machine. These control systems can either be operated via a push button system or via a touch screen using PLC control systems.

ActOn Dust Extractor for Maize Application

ActOn Dust Extractor is a self-contained collector built for collecting the fine dust resulting from the process carried out in the process chamber.

- Quick to install and easy to maintain.
- Compact design.
- Minimizes floor space and fits in virtually in any plant layout.
- Available in a standard version or with explosion relief system.
- Quiet & efficient operation.

Drive System

The work bowl, has a powerful heavy-duty, both sides extended shaft, flange-mounted vibratory motor fitted on to it to impart powerful and uniform vibrations to the mass in the bowl. Due to these vibrations, this mass moves along a rotary and spiral path inside the work bowl thereby causing the media to continuously be in contact with the components, resulting in effective processing in the shortest time.

- The vibratory motor is the heart of the machine. It is designed and manufactured to meet the duty conditions. Special castings and bearings form the assembly of these motors, making them mechanically robust and reliable.

Discharge Door

The discharge door can be used to either remove media or both media and parts based on the application. The metal door has a polyurethane cast with sealing to ensure there is no leak during the process.

The operation of the door can be done either manually or pneumatically.

Flap separation system

Due to the unique design of the flap system and the elliptical shape of the process chamber, the separation flap moves into position without catching any parts or agro media and ensures parts are not left in the work bowl during separation.

Suspension

A stable machine base incorporates special arrangement for locating the springs, therefore ensuring stability of the process chamber whilst the machine is running, without the need to bolt it to the floor.

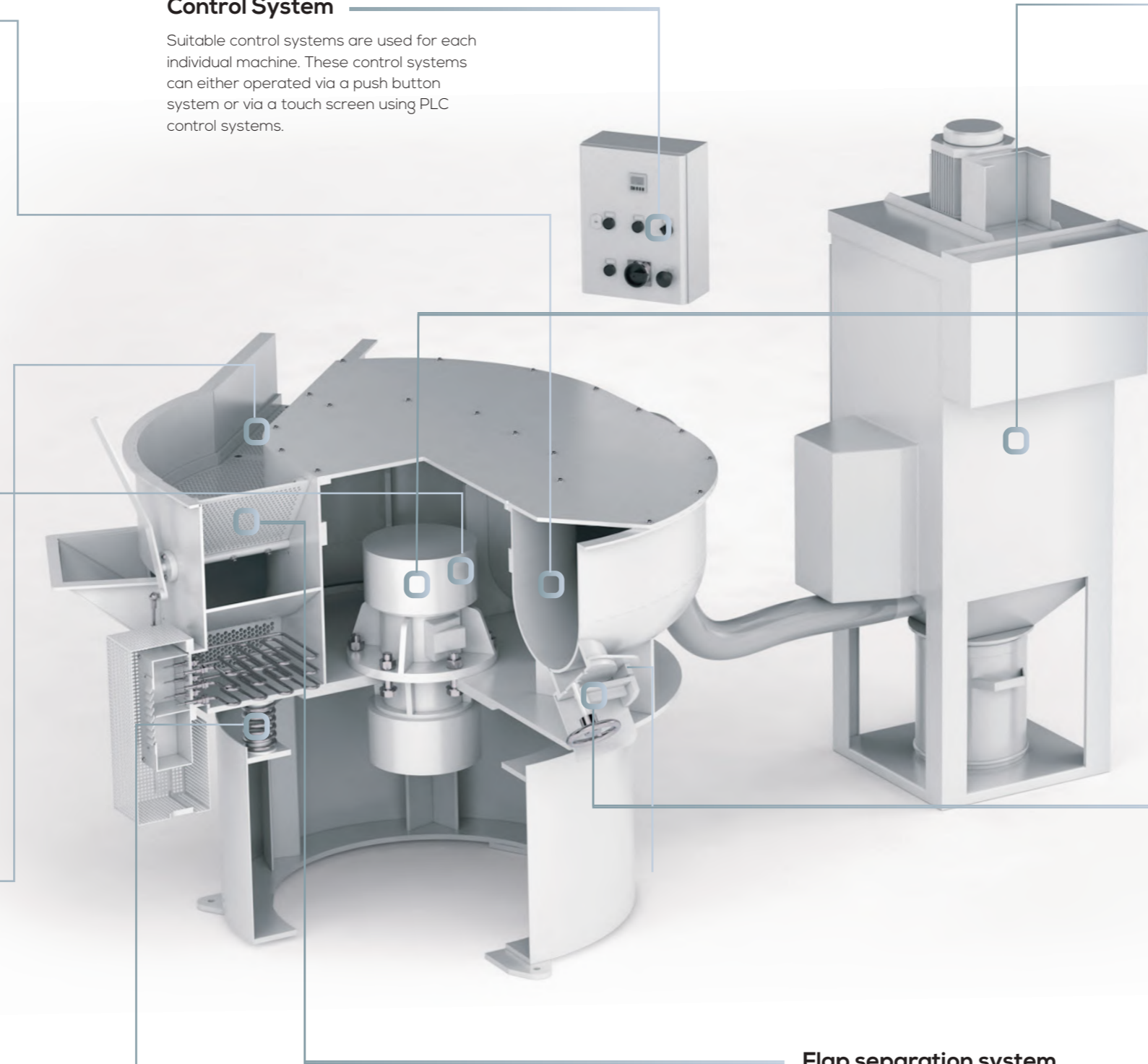

From classic size to bespoke specifications, our unique dryer machines provide solutions for every one of your drying requirements.

Our dryers can be easily integrated with the ActOn vibratory finishing machines, thus offering a complete finishing solution for your components.

ActOn dryers are also known for their 100% separation of parts and can be used as a batch process or single lap continuous process applications.

Key Benefits:

- ✓ British built, high-quality product
- ✓ Efficient in operation
- ✓ Quiet in operation
- ✓ Process results in dry and clean parts
- ✓ Operator friendly controls
- ✓ Low maintenance
- ✓ Manual / Auto functionality
- ✓ Customised to suit user applications



CD Series

The Conveyorised Electrically Heated Drying Oven is best suited for drying a variety of components, which are large in nature or where the agro media cannot be used due to the risk of lodgement. Heating is via three banks of heating elements for efficient drying. The heat is force convected by an air circulating fan motor.

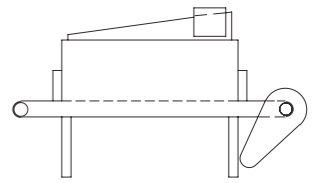

Components that need to be dried are loaded on the metal conveyor belt, which travels through the heated drying chamber and collected at the discharge end. The conveyor framework and support frame are produced from mild steel sheet, plate, rolled section or flat as appropriate and are welded and/or bolted together to form a strong and rigid structure.

Internal crossbraces are fitted where required. The head-shaft and tail-shaft are manufactured from mild steel and keywayed where necessary.

These incorporate adjustment to the belt tensioning and tracking. Shafts are supported in sealed-for-life self-aligning, ball bearings. These are driven via a geared motor having a precision chain drive to the convertor head-shaft with variable belt speed facility. The chain drive incorporates a friction type safety torque limiter and is totally enclosed in a sheet metal guard. A control cabinet oven is mounted to accommodate all necessary signal lamps, emergency stop button, push buttons, fuses and the mains isolator.

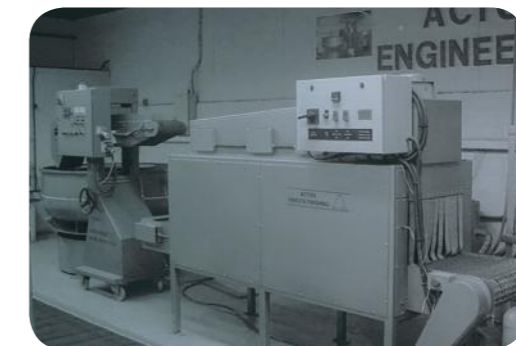

Series	Overall dimensions in mm/ inch							
	Length	Width	Height	Overall Belt Length	Heated Belt Length	Belt Length Before Heating Chamber	Belt Length After Heating Chamber	Height of Conveyor Belt
CD Series	5640 / 222	800 / 500 / 31.5 / 19.7	1875 / 73.8	3070 / 120.8	2000 / 78.7	500 / 19.7	570 / 22.4	825 / 32.5

Series	Belt Speed		Operating Temperature	Maximum Service Temperature	Max Motor Rating (kW)	Number of Heaters	Max. Heater Rating (kW)
	Max	Min					
CD Series	6mtr/M	1mtr/M	70 °C	100 °C	0.25	9	2

Sizes indicated above are standard. Custom sizes can be manufactured to suit specific applications. Dimensions are subject to change due to design improvements.

HD 3000 Series

These machines are ideally suited for small batch works and delicate components and can be used as either a batch or a continuous drying machine. The machine houses a work chamber that is polyurethane lined. The machine is mounted on castor wheels and can be moved with ease. The unit also has its media discharge door, which easily assists to empty the bowl.

The machine is quiet in operation, and runs on a standard 16A socket, 1 phase, 240V AC supply thus making it a very user friendly kit for drying or polishing operation.

Please refer to page 44 and 45 for further information on the standard and optional features available on this series of machines.

In certain applications, such as sanitation of cutlery, the UV lamp is provided on the lid which automatically engages with the lid closed.

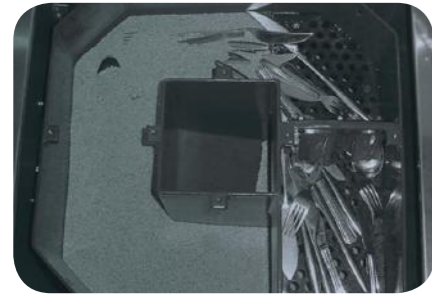

Series	Model	Capacity Cu. Ft.	Overall dimensions in mm/ inch			Chamber dimension in mm/ inch after lining			Max Motor Rating (kW)	Number of Heaters	Total Heater Rating (kW)
			Length	Width	Height	Width	Height	Length			
HD Series	HD 3000	0.63	700 / 27.5	565 / 22.2	1000 / 39.4	150 / 5.9	260 / 10.2	Spiral	0.44	1 off	1.0

Sizes indicated above are standard. Custom sizes can be manufactured to suit specific applications. Dimensions are subject to change due to design improvements.

RD Series

These Dryers are used to dry the wet components that come out of the Finishing Machine thus preventing the components from corrosion. It comprises of an inner rotating chamber where the components get dried using appropriate agro media which absorbs the moisture from the components.

- 100% separation of components and media through a fixed sieve drum.
- Re-circulation of drying media with continuous output of parts;
- The agro media can be easily changed by running the inner chamber in the reverse direction.
- Energy efficient unit with minimum loss of heat ensures effective drying and cost savings.
- Components can be fed into the dryer in batches or continuously.

- Inner barrel special design ensures parts travel from the feed end to the discharge end.



Series	Model	Overall dimensions in mm/ inch			Heating Power	Driving Power	Barrel Speeds (rpm)	Max Motor Rating (kW)
		Length	Width	Height				
RD Series	ARD 500	2085 / 82.1	1090 / 42.9	(110)1540 / (43.7) 60.6	9	0.75	7	0.75
	ARD 1000	3000 / 118	1090 / 42.9	(110)1540 / (43.7) 60.6	18	1.5	2.5	1.5

VBD Series

Simple to operate, these highly efficient machines are constructed with a component separation and discharge facility. The work chamber has an elliptical shape which gives an extra drying area, thus minimising the drying time.

optimum amount of energy to produce a finish in the most efficient manner. There are also heating elements provided to heat the drying media (maizorb) which acts as an absorbent and removes any moisture from the parts. The gentle and effective tumbling action keeps the components damage free with effective separation either via a manual flap system or pneumatically operated system to ensure 100% of the parts are discharged.

Both large and small batches of components can be processed in this machine either as a batch process or a continuous single lap process. Components are loaded in the dryer via a side loading chute. These machines are designed and manufactured with a single speed motor as a standard feature with adjustable flyweights set to transfer the

Please refer to page 44 and 45 for a range of selection on the standard and optional features on this series of machines.

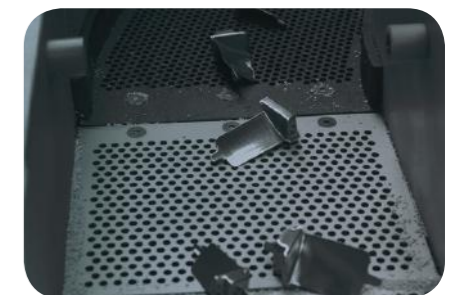
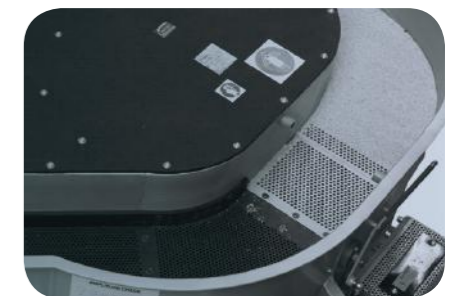
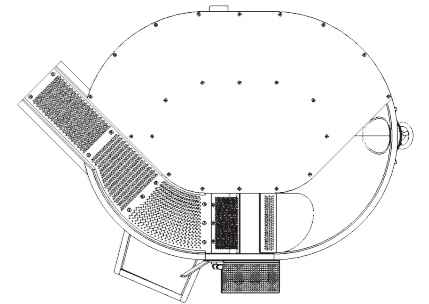
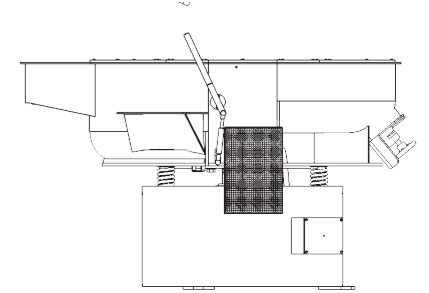

Series	Model	Capacity Cu. Ft.	Overall dimensions in mm/ inch			Chamber dimension in mm/ inch after lining		Max Motor Rating (kW)	Number of Heaters	Total Heater Rating (kW)
			Length	Width	Height	Width	Height			
VBD Series	VBD3	3	1200 / 47.2	950 / 37.4	980 / 38.6	280 / 11	300 / 11.8	1.2	2 off	2
	VBD6	6	1650 / 64.9	1315 / 51.7	1000 / 39.4	260 / 10.2	335 / 13.2	2.2	3 off	3
	VBD12	12	2000 / 78.7	1620 / 63.7	980 / 38.5	365 / 14.4	370 / 14.6	4	3 off	3
	VBD24	24	2615 / 102.9	1930 / 75.9	1150 / 45.3	392 / 15.4	425 / 16.7	7	6 off	6

Sizes indicated above are standard. Custom sizes can be manufactured to suit specific applications. Dimensions are subject to change due to design improvements.

Man x Machine x Media = M³

Automation: Vibratory bowls

Auto Deburr & Polish System

Description

This system incorporates 2 vibratory bowl finishing machines with a pneumatic unload system and it has been designed for customers manufacturing a variety of tools to suit the layout and operation.

The first machine has a clockwise unload, while the second one has an anti-clockwise unload. The height of both machines has been adjusted to enable components being unloaded from the first bowl into the second one.

The design of the system enabled the customer to carry out a 2 stage process with no operator intervention.

Advantages

- ✓ Customised design.
- ✓ Auto functionality helps carry out production out of hours.
- ✓ Multiple process stages.
- ✓ Full control of process with minimum reliance on operator.
- ✓ Suited to small and large volumes of parts.
- ✓ Can be used as a continuous or batch system.
- ✓ Savings in operating costs.

Left Hand Configuration

Process time is set for this machine to deburr the parts. At the end of the process, the machine stops and reverses the media and components to allow the separation flap to engage - thus ensuring no entrapment of parts and media under the separation flap. A complete unload and separation of parts from media is achieved automatically and components are discharged to the next sequence of the process.

PLC

To fully automate the system, including control of recipes.

Dosing Unit

(Floor-mounted or wall-mounted).

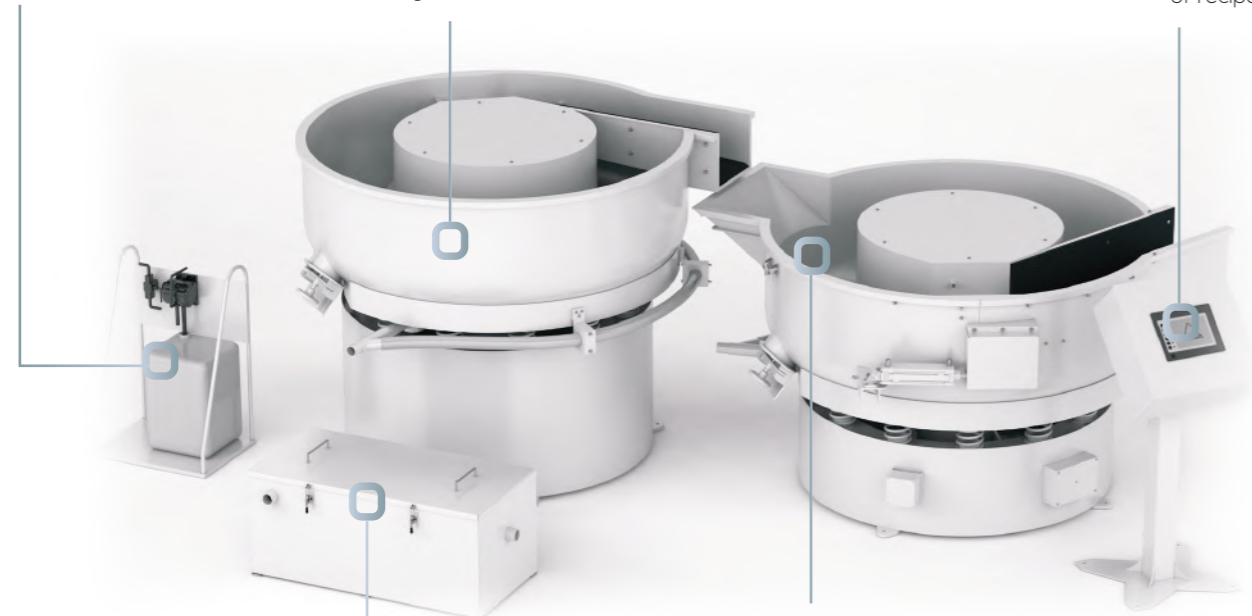

Settlement Tank

Right Hand Configuration

Upon completion of the polishing process the separation flap is engaged pneumatically, allowing vibration to unload the parts over the separation screen. The media falls through the separation screen and returns into bowl, while the parts are unloaded from the machine and suitably collected.

Auto Deburr/ Polish and media recirculation

Top up and dewatering system for automotive part application.

Description

This system has been designed to ensure 100% discharge of media and parts at the end of the process. On completion of the process, the pneumatically operated door on the bowl machine opens to allow for all the contents from the bowl to be discharged fully.

As our customer required minimum reliance on an operator, the system has been fully automated for repeatability.

Advantages

- ✓ A fully automated system designed and manufactured to ensure process control and repeatability.

Vibratory Parts Feeder with Weight Control

Ensures excessive parts are not loaded to the process.

Vibratory Bowl

Specially designed with a pneumatic door for complete discharge with a semi-hinged acoustic lid.

Parts and Media Conveyor

Used to convey the parts to the bowl and also serves as a media return conveyor.

PLC and HMI Controls

Controls all equipment and process in the system from start to finish. Alpha-numeric part number specific recipes can be programmed. Maintenance schedules with alarms programmed for preventative maintenance. All password protected.

Vibratory Separation System

Separates media from parts.

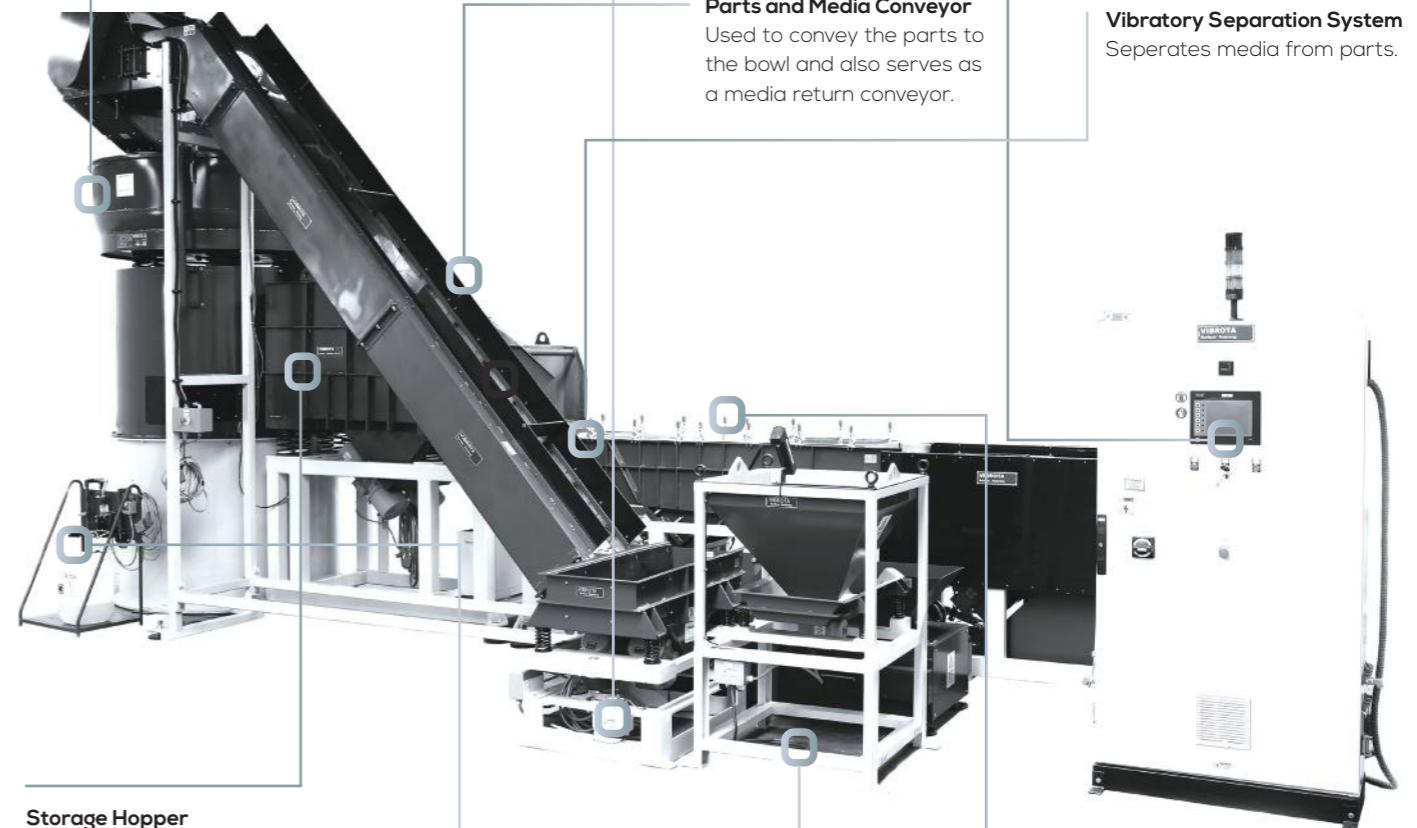

Storage Hopper

Used as an intermediate storage hopper and feeder for controlled feed to separation system.

Top Up Media Hopper

Automatically dispenses replenishment media based on wear rate.

Dosing Unit

(Floor-mounted or wall-mounted).

Dewatering Screens Feeder

Incorporates a recirculation tank with pump and special spray system on the feeder for enhanced protection of the parts.

Vibratory Finishing System

Description

The system has been designed and custom built to deburr and avoid impingement damages to the part during the process. The system is used to process stainless steel and aluminium components with weights ranging from 30 grams to 5 kilograms each. The process is fully automated and controlled from the point of feed to discharge. Suitable interlocks are provided to control the feed system and integrate with this Vibratory Finishing System.

Advantages

- ✓ A fully automated system designed and manufactured to ensure process control and repeatability. This system can be integrated with on line processing of parts and can be integrated with drying systems as required.

Air Knife System

Integrated with the activation of the unload system of the flap on the vibratory bowl. This system ensures no media chips are carried forward out of the screening area, which otherwise stick to the components due to surface tension.

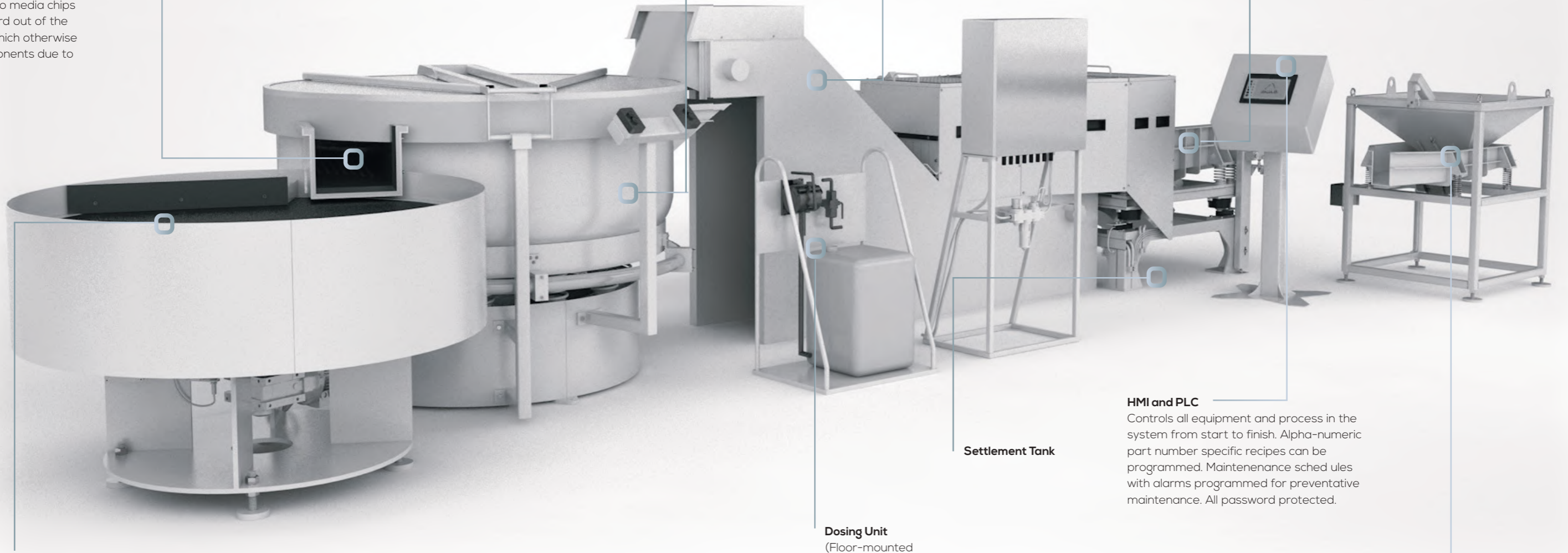

Vibratory Bowl Finishing Machine

Built to suit functionality of pneumatically operated auto discharge post process with reverse motor movement to ensure complete unload of parts. Heavy duty flap system to handle part weight and special designed screen with poly coating to suit media size and shape. Dual drain in the bowl assists in a cleaner process and reduced maintenance hours for cleaning.

Parts and Media Conveyor

Facilitates transfer of components for the next process and also the replenishment media as per recipe control.

Vibratory Parts Feeder with Weight Control

This unit is a recipient of the components that require processing. Components are stored initially to the set weight and then gradually transferred to the conveyor system. There are pneumatically operated control gates on this unit to regulate the flow of parts and hence avoids impingement damages.

HMI and PLC

Controls all equipment and process in the system from start to finish. Alpha-numeric part number specific recipes can be programmed. Maintenance schedules with alarms programmed for preventative maintenance. All password protected.

Settlement Tank

Dosing Unit
(Floor-mounted or wall-mounted).

Top Up Media Hopper

Automatically dispenses replenishment media based on wear rate.

Rotary Table

Is used to collect components post process. Provides an ergonomic surface which the operator can sort, visually inspect and collect the parts into their respective containers.

Man x Machine x Media = M³

Automation: Linear Troughs

TU 4500 Linear Troughs with media return system

Description

The ActOn Linear Trough Series machine is unique in design and meets the highest standards. It is a through feed machine with automatic media return. The parts are fed from one end and discharged from the other end making this equipment suitable for continuous output.

Components requiring deburring and descaling are - either manually or via an auxiliary system - fed into the vibratory trough. The parts travel all along the length of the trough

with a mixture of compound fed from the recirculating tank that is built as an operator platform and media to deburr and descale parts post heat treatment. At the end of the trough there is a vibratory screening system to separate the parts from the media. The media is transferred back to the work chamber via the conveyor and a feeder.

Control system could be either PLC with HMI or Push buttons.

Capacity		Overall dimensions in mm/ inch			Trough dimension in mm/ inch after lining			Max Motor Rating (kW)
Cu. Ft.	Litres	Length	Width	Height	Length	Width	Height	
27	785	6585 / 259	2200 / 87	2280 / 90	4000 / 158	490 / 19	600 / 24	11.25

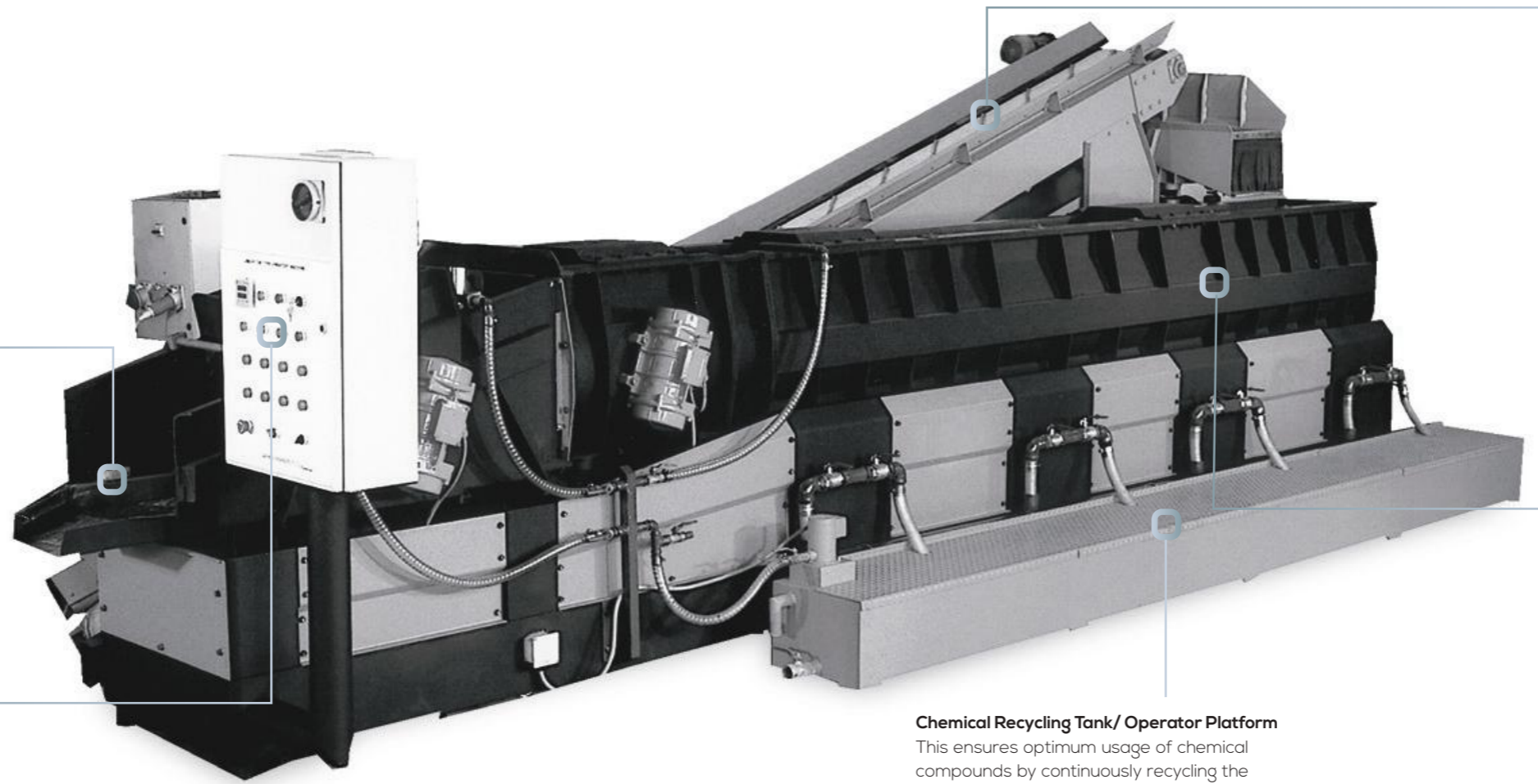

Vibratory Separation System

Upon completion of the process, parts and media are slowly fed into the vibratory system. The media falls through the separation screen and returns into the feeding end via the media conveyor, while the parts are unloaded from the machine.

PLC

PLC to control the system. Offers the option to pre-set recipes for processing the parts.

Media Return Conveyor

This has been integrated to carry the media from the vibratory media feeder into the finishing machine. The main advantage of the conveyor is that it reduces the manual handling, hence reducing the time spent to load the machine.

Vibratory Linear Trough Finishing Machine

The machine capacity is 785L. The process chamber has a hot, cured polyurethane lining and is used to deburr, descale, radiusing and cleaning the parts. To control the speed of the media and parts, a flow control system has been installed. The unload of the components is made through a vibratory separation system.

Chemical Recycling Tank/ Operator Platform

This ensures optimum usage of chemical compounds by continuously recycling the compound into the bowl from the tank. A combination of pump and valves control the recycling process. The tank has been designed to also be used as a platform for ease of access to the work chamber.

Man x Machine x Media = M³

Automation: Dryer

VB20M machine with magnetic separation and conveyorised oven

Description

This system was designed for the processing of knives. However, the system can be incorporated on ferrous components where parts and media are of a similar size, by which standard separation is not possible. The parts are processed in the M series machines. Post completion, the

parts are separated magnetically by the electromagnetic separator. The machines have a raised hump, thus allowing complete separation of small and large components. The parts are then transferred onto the conveyorised oven, which dries the parts. A maize dryer can be used instead of the oven.

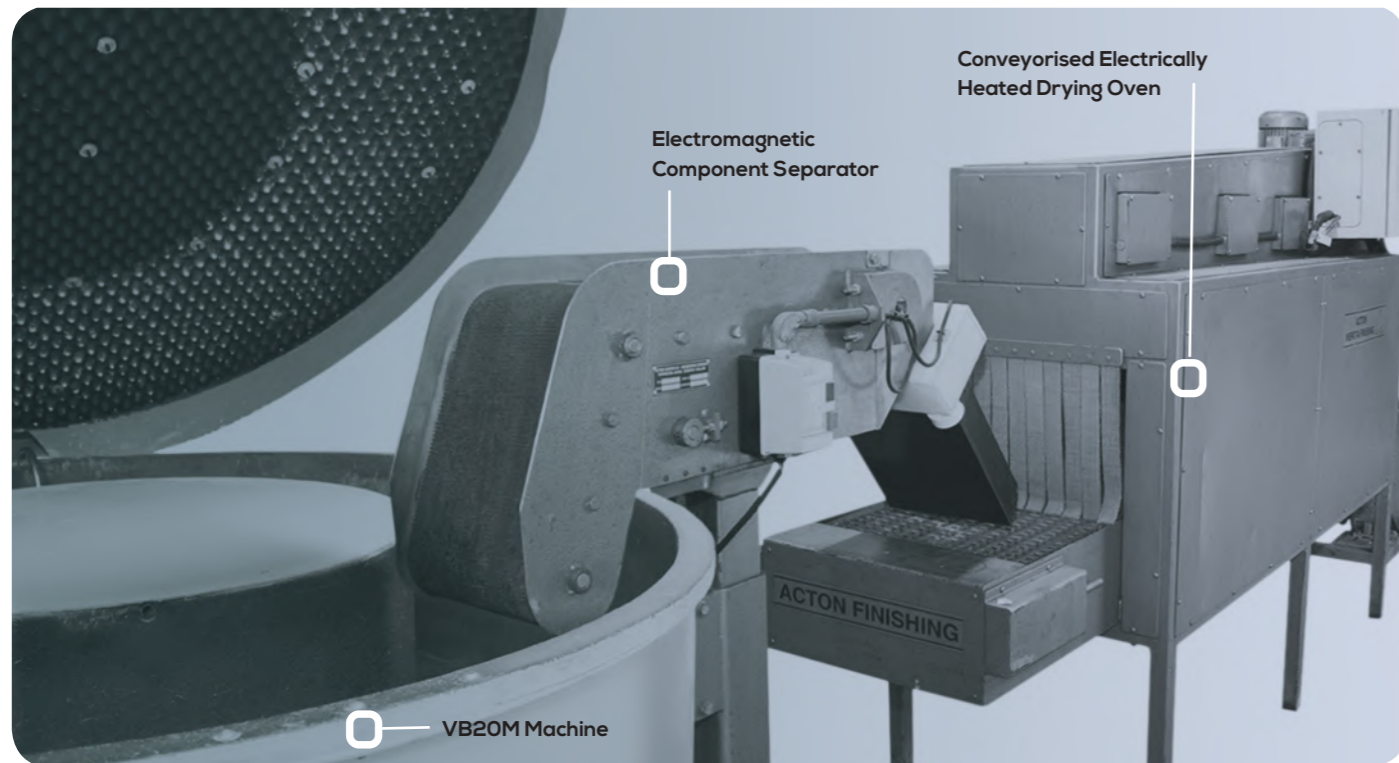

Cutlery polishing and drying system

Description

This system is designed for the polishing and drying of cutlery.

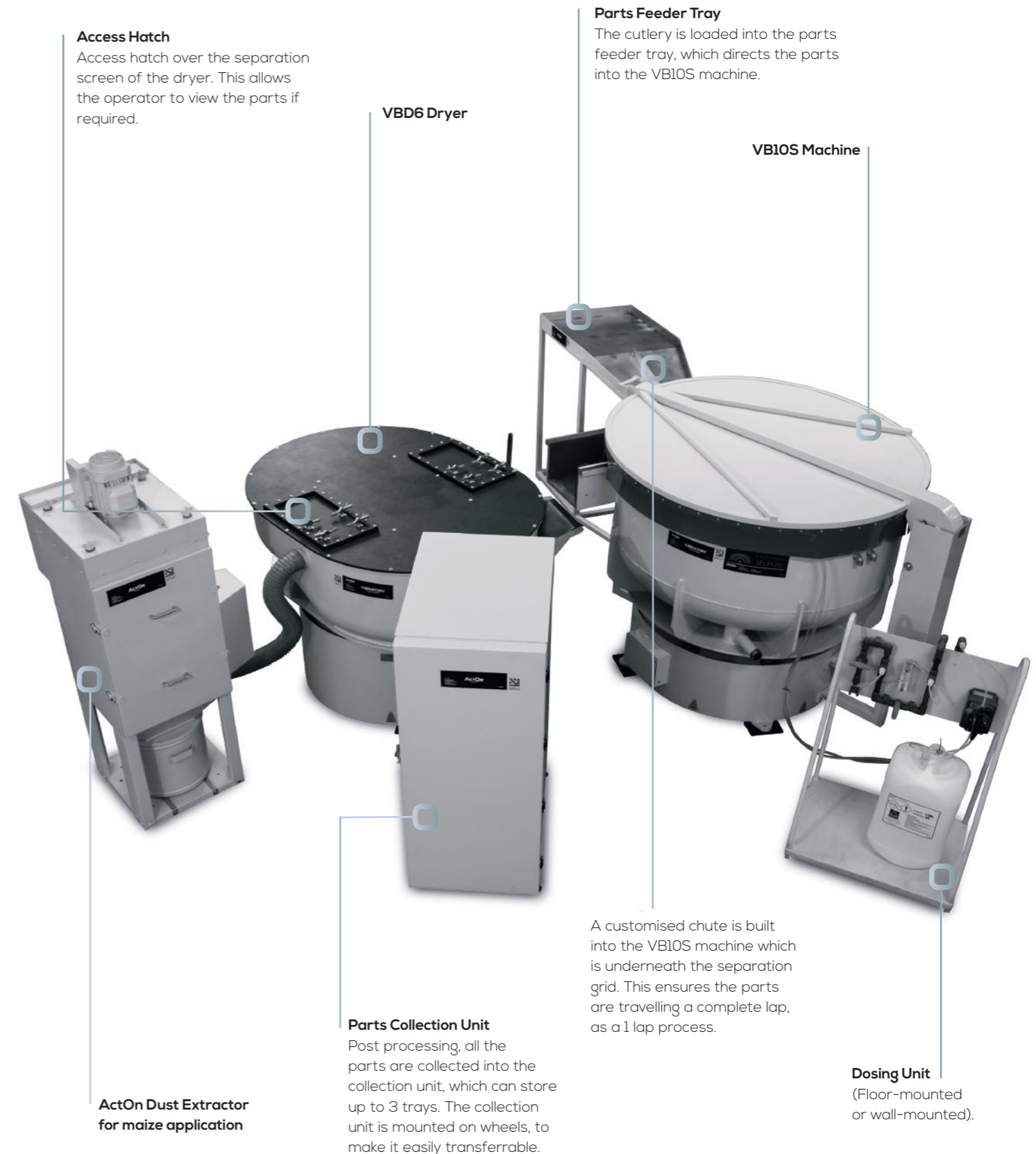

Access Hatch

Access hatch over the separation screen of the dryer. This allows the operator to view the parts if required.

VBD6 Dryer

Parts Feeder Tray

The cutlery is loaded into the parts feeder tray, which directs the parts into the VB10S machine.

VB10S Machine

ActOn Dust Extractor for maize application

Parts Collection Unit

Post processing, all the parts are collected into the collection unit, which can store up to 3 trays. The collection unit is mounted on wheels, to make it easily transferrable.

A customised chute is built into the VB10S machine which is underneath the separation grid. This ensures the parts are travelling a complete lap, as a 1 lap process.

Dosing Unit

(Floor-mounted or wall-mounted).

Vibrota Range

	Bowls						Troughs					Duals	Driers	
	VBI	VBIS	B	C	I	M	O	P	S	TU	HT		VBD	HD
	Acoustic Lid													
Manually Operated	○	○	○	○	○	+	○	○	○	○	○	+	○	
Pneumatically Operated			+	+	+	+	+	+	+					
Discharge Door														
Manually Operated			○	○	○	○	○	+	○	○	○	○	○	
Pneumatically Operated			+	+	+	+	+	○	+	+	+	+		
Separation														
Manual Separation System		○	○						○			○	○	
Pneumatic Separation System			+						+			+	+	
Magnetic Separation System												+		
Undersize Media Separation			+	+	+	+			+			+		
Air Knife			+						+			+		
Spray System			+						+			+		
Motor														
Single Speed	○	○	○	○	○	○	○	○	○	○	○	○	○	
Variable Speed		+	+	+	+	+	+	+	+	+	+	+		
Control Systems														
Standard Controls	○	○	○	○	○	○	○	○	○	○	○	○	○	
PLC/HMI Controls			+	+	+	+	+	+	+			+		
Lining														
Polyurethane Lining	○	○	○	○	○	○	○	○	○	○	○		○	
Wedge Lining		+	+	+	+	+	+	+	+	+	+			
Rubber Lining			+											
Accessories														
Dosing	+	+	+	+	+	+	+	+	+	○	+			
Settlement Tank	+	+	+	+	+	+	+	+	+		+			
Recirculation Tank	+	+	+	+	+	+	+	+	+	○	+			
Batch Centrifuge			+	+	+	+	+	+	+		+			
Dust Extractor											+	+	+	
Divider Plates					○				+	+				

The above accessories are the most commonly used. Please refer to our accessories brochure for more options along with detailed description.

+ Optional ○ Standard

Value Added Service

On top of our state-of-the-art machinery and media, we also supply a range of support and training services.

Learn more on how you'll benefit:



Waste Water Treatment

During the finishing operation, the effluent can be polluted with oil, media and metal fines. It is critical that the effluent must be treated before going to drain, or if it is being recycled back into the system. Each area or district has its own discharge consent, hence the effluent must be analysed against this.

The effluent can be recycled, however there are certain applications where it is not possible. In those cases, the treated effluent can be transferred directly to the drain. Recycling can save on the significant amount of water and compounds (greater than 90%) used.

We offer a range of flocculants (powder and liquid) coupled with our Centrifugal technology. Please refer to our waste water treatment brochure for more details.

Subcontract Services

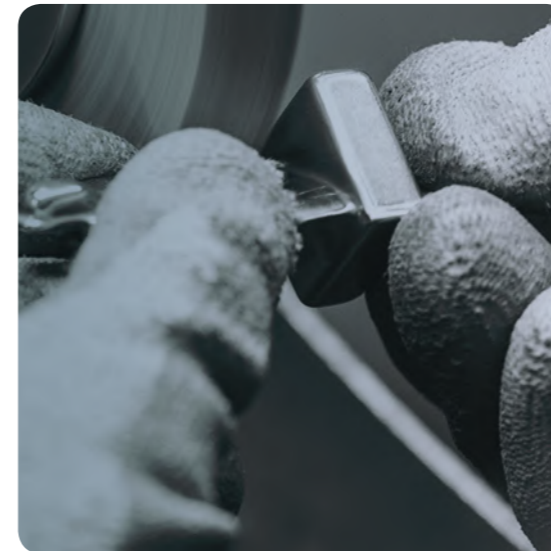

Precision Polishing

In order to provide you with complete surface finishing solutions, we offer a precision polishing service for components from various industry sectors. In combination with our barrelling capability, you'll benefit in terms of cost, delivery and quality. Our applications include removal of manufacturing defects on femurs and aerofoils, which are inherent in the casting and forging process.

Inspection

Our trained inspectors ensure every component is inspected to the required specification prior to delivery. The inspections can include visual, dimensional and surface finish measurements. Our document controls ensure that all inspections are recorded for traceability purposes.

High Energy and Vibratory Finishing Services

Our factory is well equipped with High Energy (HE) and Vibratory machines, which are designed and manufactured by our Engineers. The HE machines provide a speedy finishing solution, as well as a high quality finish to the parts, eliminating any need of fixturing and preventing their impingement. Along with the HE machines we also have Vibrota finishing equipment, which processes parts of variable sizes and batch quantities.



After-sales, Training and Installation

We hire a number of highly trained staff, including engineers, who are on-call for all of your after-sales requirements. From installation and training, to maintenance and prompt professional advice, our finishing specialists are here for you every step of the way.



What Our Customers Say

“ ActOn have revolutionised the way we finish, saving us time and money with the use of their machines and media. ”

“ From developing a bespoke process, to installing machines and training our staff, ActOn were excellent throughout. ”

“ I have been running this machine for over 10 years, and it’s still going.”

Quality You Can See

We pride ourselves on our excellence, and over the years we have successfully demonstrated an ongoing compliance with ISO quality and environmental standards.

For ISO, we currently hold:



We're proud members of the 'Made in Britain' campaign.

we redefine

ActOn Finishing Limited
213 Torrington Avenue
Tile Hill, Coventry, CV4 9HN, UK.

+44 (0) 24 7646 6914
enquiries@acton-finishing.co.uk
www.acton-finishing.co.uk